

bühler

allied

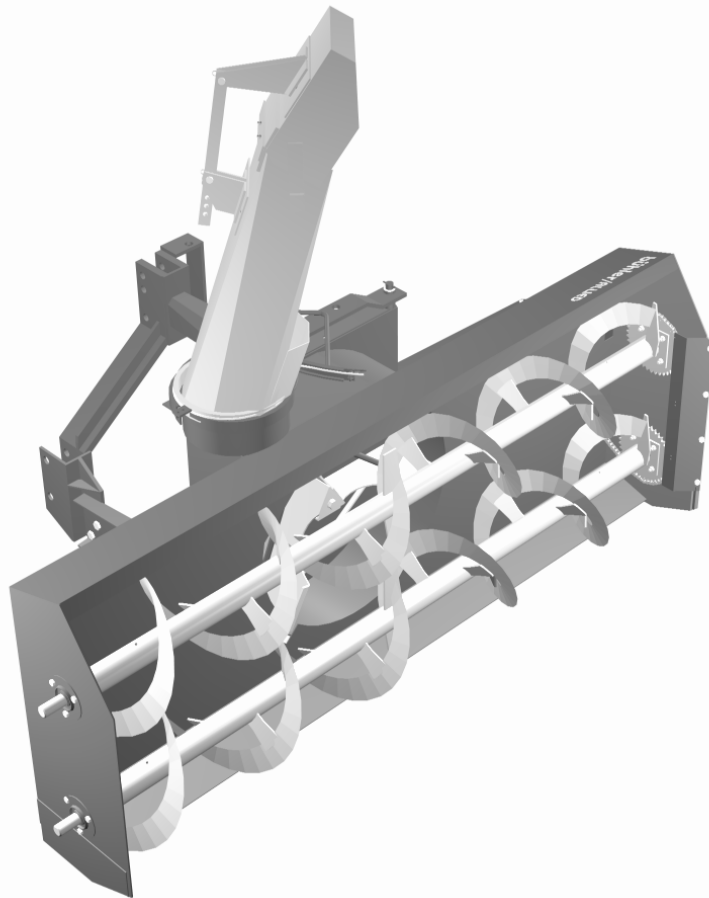

96" Snowblower

Operator's and Parts Manual
FK330

2008

TABLE OF CONTENTS

DESCRIPTION	PAGE
Warranty	1
Safety Instructions & Safety Sign Locations	2
Operating Instructions.....	3
Assembly Instructions	5
96" Allied Snowblower Drawings.....	8
96" Allied Snowblower Parts List	10
96" Allied Snowblower PTO Drawing	12
96" Allied Snowblower PTO Parts Lists	13
Gearbox Assembly Drawing & Parts List	15
Cylinder Assembly Drawings & Parts Lists	16
Shipping Kit and Bundle Numbers	17

WARRANTY POLICY

Buhler Manufacturing products are warranted for a period of twelve (12) months (90 days for commercial application) from original date of purchase, by original purchaser, to be free from defects in material and workmanship under correct, normal agricultural use and proper applications.

Buhler Manufacturing's obligations under this warranty shall be limited to the repair or exchange, at Buhler Manufacturing's option, of any Buhler Manufacturing product or part which proves to be defective as provided. Buhler Manufacturing reserves the right to either inspect the product at the buyer's location or have it returned to the factory for inspection.

The above warranty does not extend to goods damaged or subject to accident, abuse or misuse after shipment from Buhler Manufacturing's factory, nor to goods altered or repaired by anyone other than an authorized Buhler Manufacturing representative.

Buhler Manufacturing makes no Express Warranties other than those, which are specifically described. Any description of goods, including any references and specifications in catalogues, circulars and other written material published, is for the sole purpose of identifying goods and shall conform to such descriptions. Any sample or model is for illustrative purposes only and does not create an Express Warranty that the goods conform to sample or model shown.

The purchaser is solely responsible for determining suitability of goods sold. This warranty is expressly in lieu of all other warranties expressed or implied. Buhler Manufacturing will in no event be liable for any incidental or consequential damages whatsoever. Nor for any sum in excess of the price received for the goods for which liability is claimed.

WARRANTY CLAIMS:

Warranty requests must be prepared on Buhler Manufacturing Warranty Claim Forms with all requested information properly completed. Warranty Claims must be submitted within a thirty (30) day period from date of failure repair.

WARRANTY LABOR:

Any labor subject to warranty **must** be authorized by Buhler Manufacturing. The labor rate for replacing defective parts, where applicable, will be credited at 100% of the dealer's posted shop rate. Defective parts will receive an extra 10% discount to assist with freight or other incidental costs.

GOVERNMENT LEGISLATION:

Warranty terms and conditions are subject to Provincial or State legislation.

IMPORTANT FACTS:

Buckets and Bucket Tines Carry No Warranty
Bent Spears Carry No Warranty
Snowblower Fan Shafts Carry No Warranty
Mower Blades Carry No Warranty
Portable Auger Parts Have Two (2) Year Warranty
Loader Parts Have Two (2) Year Warranty

IMPORTANT NOTE: This warranty does not apply to rentals

SNOWBLOWER

This manual is for 96" Allied Snowblower with a quick coupling hitch. With this hitch, the blower can be mounted on a tractor with either a quick hitch or the standard three-point hitch. All 96" Allied snowblowers have a sealed oil bath gearbox. The snowblower is the push type and will mount to a tractor with 540 rpm PTO. It is supplied with category 2 pins with conversion bushings to category 3 available. This 96" wide snowblower comes with hydraulic chute control as standard equipment. A hand crank chute control is available. There is a shear bolt on the auger and on the PTO shaft to protect the machine from damage if a large object is picked up. Any smaller objects in the snow will be thrown with it and could cause serious injury. Do not let anyone stand behind the tractor in the area of the discharged snow.

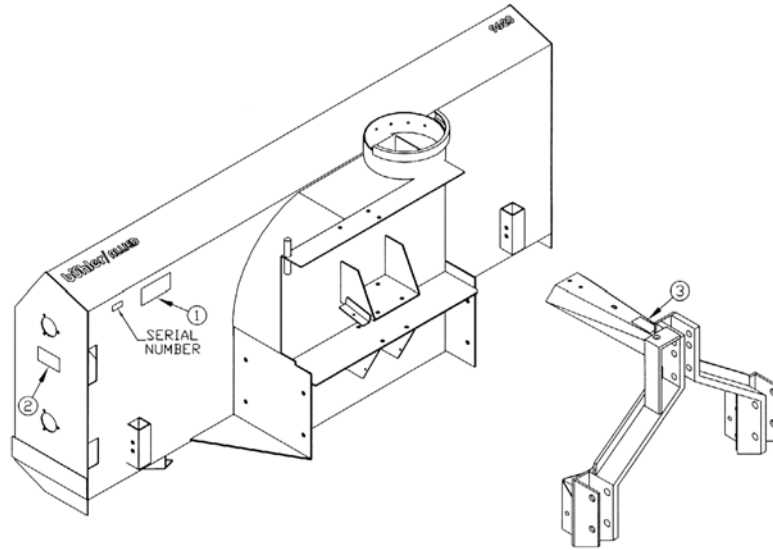

 CAUTION
<ol style="list-style-type: none"> 1. Keep all shields in place. 2. Disengage all power when servicing or unplugging machine. 3. Keep hands and clothing away from all moving parts.
963206

#1

Replace safety signs immediately should they become damaged, torn or illegible. Obtain replacements from your authorized dealer using the part numbers shown.



 WARNING
<p>CHECK PTO SHAFT LENGTH BEFORE RAISING OR LOWERING IMPLEMENT. SHAFT MUST NOT BOTTOM OR SEPERATE (SEE MANUAL)</p>
108431

#3

 DANGER
<p>STAND CLEAR WHEN MACHINE IN OPERATION</p>
102893

#2

OPERATING INSTRUCTIONS

1. Do not operate the blower in the fully raised position. The three-point hitch on some tractors rises high enough to cause the PTO shaft to bind. This can cause damage to the PTO shaft and/or to the hitch and pins.
2. Depth of cut can be partially controlled by tilting the blower forward or backward. Adjust the tractor quick hitch so the snowblower is just slightly tilted back when resting on the ground.
 **CAUTION:** Excessive backward tilt may cause the "U" joints to flutter resulting in PTO shear bolt failure.
3. Run the blower at low rpm to check operation before blowing snow.
4. The snowblower has two shear bolts to protect the tractor and blower in case a large object enters the blower. PTO shear bolt - two 5/16" x 1" (Grade 8); Auger shear bolt – 5/16" x 1 1/4" (Grade 5). Shear bolts should be fastened with a lock nut or two jam nuts. These bolts must be kept tight to prevent wear of the bolt and bolt holes.
5. Never run PTO shaft at over 600 rpm.
6. Chain Tension: Slack on the lower side of the chain should be 3/8" to 1/2".
7. Lubrication:
 - a) The spout clamps and rings should be periodically lubricated with gun grease.
 - b) PTO shaft universal joints and square shaft slide should be greased daily.
 - c) Regularly oiling the chain will significantly increase the life of the chain.
 - d) The grease fitting on the hydraulic spout swivel arm should be kept lubricated.
 - e) Gearbox - Use any 80-90 gear oil or multigrade with 80 minimum.
8. Periodically check all bolts for tightness. The bolt holding on the fan and the bearing bolts are of particular importance.
9.  **Danger:** Always stop blowing for servicing or unplugging. The PTO Should be disengaged before dismantling from the tractor.
10.  **Caution:** Always check to see that both ends of the PTO shaft are securely attached as per instructions every time you are preparing to use the Snowblower.

OPERATING INSTRUCTIONS – cont'd

11. Shear Sprocket: The shear sprocket (#24) should be checked at the beginning of every season to make sure it will spin freely. With time this sprocket could corrode and seize which will not allow the shear bolt to break if something jams in the snowblower auger. Clean to loosen if necessary.
12. When replacing bearings or tightening a loose bearing collar, always tighten collar in the direction of shaft rotation using a center punch or a similar tool.

ASSEMBLY INSTRUCTIONS

1. Fasten the two quick hitch arms (#57) to the main body. Use eight 5/8" x 1 1/4" hex bolts, lock washers and hex nuts. **Note:** Lift arms for quick coupling hitch are 30 3/4" long versus 35" for the standard three point hitch.
2. Bolt the quick hitch (#56) to the snowblower body using two 1/2" x 1 1/4" hex bolts, lock washers and hex nuts. Fasten to the lift arms using three 5/8" x 1 1/2" hex bolts on each lift arm. Insert a 1" top link pin at the top and two 1 1/8" lift pins at the bottom of the hitch.
3. Bolt the hitch cross brace (#2) underneath the two quick hitch arms using two 5/8" x 1 1/2" hex bolts, lock washers, flat washers and hex nuts.
4. Mount the discharge spout (#3) using the spout clamp (#51) bolted to the spout ring on the snowblower. Lubricate the spout ring and clamp.
5. Hydraulic Spout Swivel:
 - a) Mount the swivel arm (#36) onto the swivel pin welded to the back corner of the fan housing using a 1" ID flat washer (#37) and a 3/16" x 1 1/2" cotter pin (#52).
 - b) Wrap cable (#35) around spout and clamp to the ends of the swivel using 1/4" cable clamps (#16).
 - c) With the spout turned forward and the swivel arm centered with the spout, clamp the cable to the spout cable anchor using another cable clamp. Ensure that the spout is not jammed and that there is no slack in the cable.
 - d) Use a standard 8" stroke cylinder (20 1/4" min., 28 1/4" max. pin centers).
 - e)  **NOTE:** A hydraulic cylinder and hose kit to control the spout deflector is available as an option.
6. Hand Crank (Option):
 - a) Fasten hand crank assembly (#50) using two 1/2" x 1 1/4" hex bolts, lock washer and hex nuts.
 - b) Thread cable (#53) through hole in hand crank to even lengths and wrap around the tube to each side of the hole four turns in opposite directions.
 - c) Turn spout to center forward position and clamp cable to cable anchor on far side of spout using clamp (#16).

ASSEMBLY INSTRUCTIONS – cont'd.

7. Mounting blower on tractor:
 - a) The pins supplied with the snowblower are for a category 2 quick hitch. The quick coupling hitch has two holes both at the top of the hitch and at each lift arm. When using a quick coupler, the pins must be in the inside set of holes. Use the outside set of holes with a standard three-point hitch.
 - b) Using tape or a bright colored marking pen, mark on the outer shields the position where the shaft is completely pushed together and the position where you have a 4" overlap. Watch these marks when moving the blower through all possible operating angles to see that the PTO shaft stays within this range.
 - c) With the engine on the tractor shut off, attach the PTO shaft. The tractor end has a standard 6-spline end with a spring loaded locking collar. The snowblower end has a clamp-style yoke with a 3/8" key way. Slide the yoke onto the gearbox shaft with the 3/8" key supplied. Lock the yoke in place with the 1/2" x 3" hex bolt and lock nut fitted through the groove in the gearbox shaft. After tightening the bolt, insert and tighten the 3/8" socket set screw supplied.

⚠ Caution: Always check to see that both ends of the PTO shaft are securely attached every time the Snowblower is used. This should always be done with the tractor engine off.
 - d) Check that the PTO shaft does not bottom or separate with the blower in the extreme high and low positions. A longer optional PTO shaft is available if the standard shaft is too short. Check for free movement of all parts in various raised positions; particularly the PTO shaft.
 - e) **NOTE:** Excessive U-joint wear and shear pin failure may result if the tractor PTO angle exceeds 20°. The drawing below gives an approximate way to check this angle. With the PTO half extended, the tractor output should not be over 32 inches high. Use 34 inches if the PTO is nearly fully extended and 30 inches if it is nearly compressed.

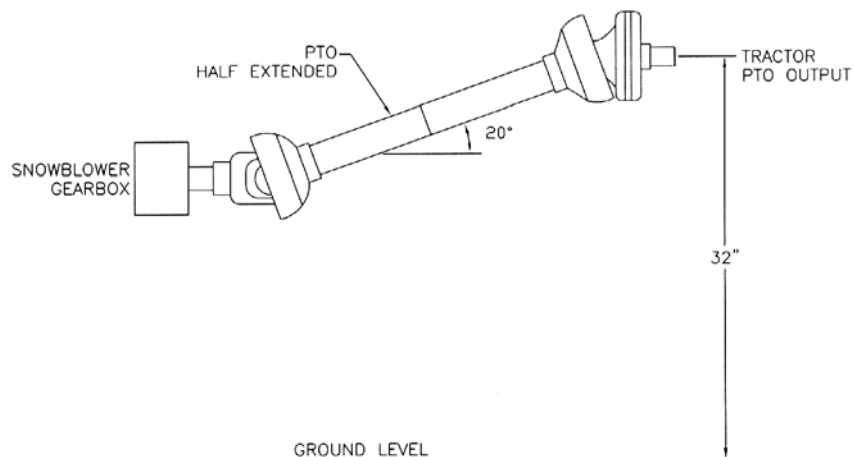

SB-26

ASSEMBLY INSTRUCTIONS – cont'd.**8. PTO SHIELD**

All snowblowers are supplied with a PTO shield (#61). To install, remove the two rear bolts at the top of the gearbox (#38). Bolt the PTO shield to the gearbox by the hinges using these same bolts. A utility spring (#62) keeps the shield in place. Hook one end of the spring in the hole in the shield and the other end to the hole in the brace under the gearbox.

⚠ CAUTION: Do not run the snowblower without this shield in place.

REFILLING GEARBOX WITH OIL:

If the gearbox requires refilling with oil because of repairs to the gearbox, add oil to the level shown in drawing. Check the level regularly using the plug in the lid. The correct level is even with the bottom of the plug.

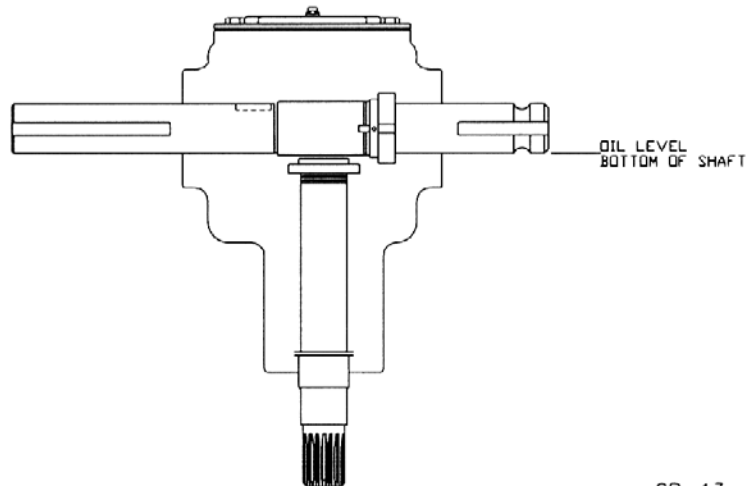

SB-13

96" SNOWBLOWER W/QUICK HITCH

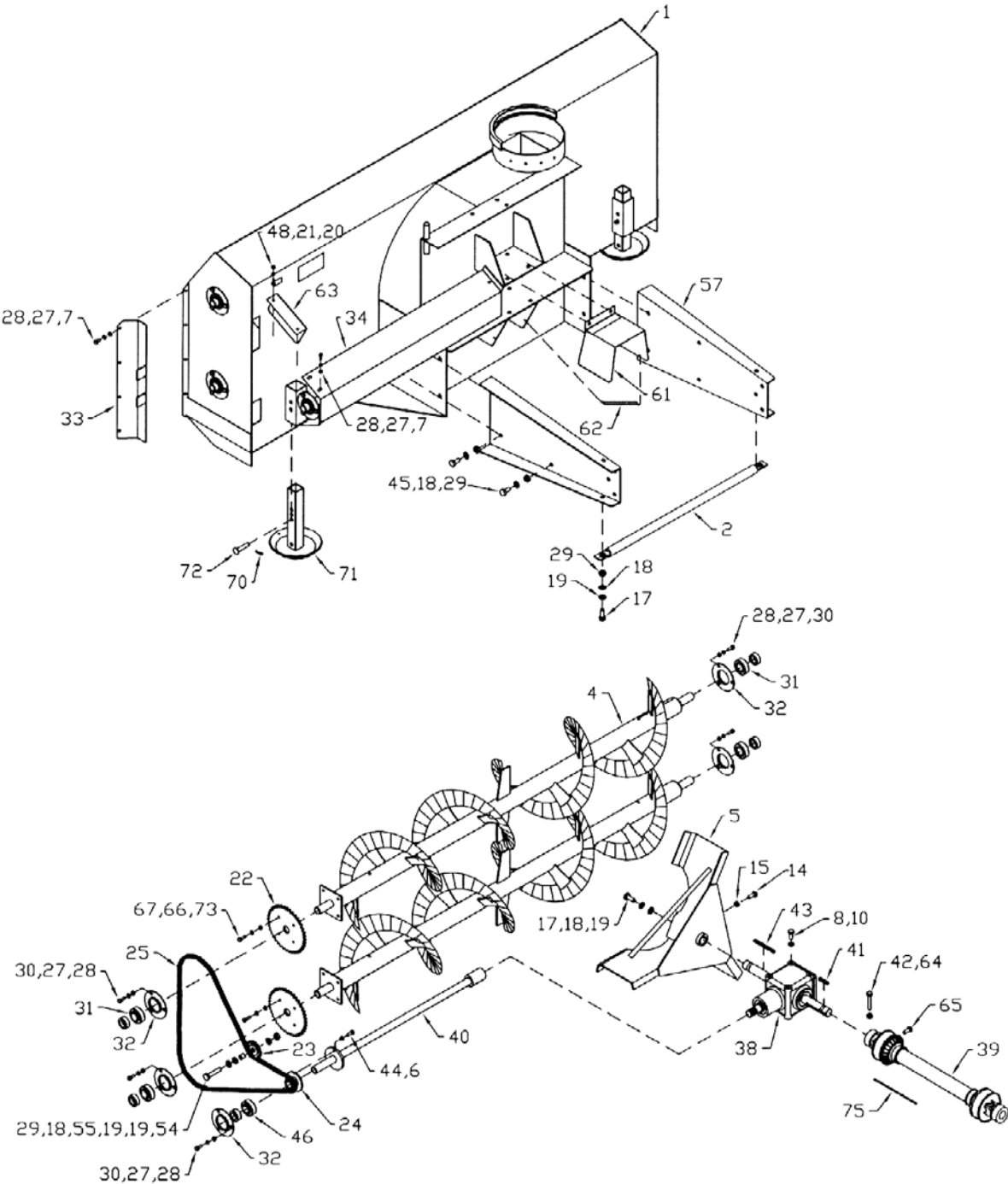

SB-21

WHEN ORDERING PARTS

Always give your dealer the Model, Color and Serial Number of your machine to assist him in ordering and obtaining the correct parts. Use the exploded view and tabular listing of the area of interest to exactly identify the required part.

96" ALLIED SNOWBLOWERS

ITEM	PART #	DESCRIPTION
1	902403A	Main Body
2	965959A	Hitch Cross Brace, 1 1/2" x 39 1/2"
3	965648	Spout Weldment
4	965904	Auger
5	965905	Fan Assy (Standard 3-Blade)
	965448	Fan Assy (Optional 4-Blade)
6	812362	5/16" Lock Nut (pl)
7	84072	3/8" x 3/4" Hex Bolt (pl)
8	81619	1/2" x 1" Hex Bolt (pl)
9	81620	1/2" x 1 1/4" Hex Bolt (pl)
10	81637	1/2" Lock Washer (pl)
11	81636	1/2" Hex Nut (pl)
12	965910	Top Link Pin (Cat. 2)
13	965911	Linch Pin
14	84111	1/2" x 1 1/4" Sq. Hd. Set Screw (pl)
15	984077	1/2" Jam Nut (pl)
16	961658	1/4" Cable Clamp
17	84268	5/8" x 1 1/2" Hex Bolt (pl)
18	81677	5/8" Lock Washer (pl)
19	81678	5/8" B.S. Flat Washer (pl)
20	81569	5/16" Lock Washer (pl)
21	81568	5/16" Hex Nut (pl)
22	965912	40 Tooth Sprocket, #60, 1 3/8" Bore
23	965962A	Idler Sprocket, #60 x 13 Tooth
24	965914A	13 Tooth Sprocket, #60, 1 1/4" Bore
25	965972	Roller Chain (#60 x 117 Link w/ Conn & Offset)
26	961876	1/2" x 1 1/2" Clevis Pin (pl)
27	81593	3/8" Lock Washer (pl)
28	81592	3/8" Hex Nut (pl)
29	81676	5/8" Hex Nut (pl)
30	86170	3/8" x 1" Hex Bolt (pl)
31	965917	1 3/8" Bearing w/ Collar
32	961675A	Flange Bearing (72MS)
33	965963A	Chain Guard
34	965919A	Drive Shaft Guard

35	965964	1/4" Cable x 70" Long
36	965923	Swivel Arm
37	967140	1" x 10ga Narrow Rim Washer (pl)
38	BU50505	Gearbox Complete w/o Oil
39	F0585	PTO Shaft Complete
40	965925A	Drive Shaft
41	968807	3/8" x 3/8" x 2" Key
42	81627	1/2" x 3" Hex Bolt (pl)
43	902377	3/8" x 3/8" x 4 3/4" Key
44	81552	5/16" x 1 1/4" Gr. 5 Hex Bolt (pl)
45	811702	5/8" x 1 1/4" Hex Bolt (pl)
46	961676	1 1/4" Bearing w/ Collar
47	967164	Pound-In Grease Fitting
48	81549	5/16" x 3/4" Hex Bolt (pl)
49	81620	1/2" x 1 1/4" Hex Bolt (pl)
50	965803	Hand Crank Weldment
51	965970A	Spout Clamp
52	9812433	3/16" x 1 1/2" Cotter Pin (pl)
53	965927	3/16" Cable x 100" Long
54	84289	5/8" x 3" Hex Bolt (pl)
55	965928A	Idler Spacer, 3/4" Long
56	FX9204	Allied Quick Hitch
57	965952A	Quick Hitch Arm
59	812026	5/16" x 1" Hex Bolt (pl)
60	965966	Quick Hitch Lift Pin (Cat. 2)
61	908715	PTO Shield
62	960135	PTO Shield Spring
63	965968	Idler Shield
64	812364	1/2" Lock Nut (pl)
65	988999	3/8" x 3/8" Socket Set Screw (br)
66	81593	3/8" Lock Washer (pl)
67	81592	3/8" Hex Nut (pl)
68	965646	Spout Adjustment Bar
69	903523	1/2" x 1 1/2" Adjustment Pin Weldment
70	961012	#16 Hair Pin Clip
71	902407	Skid Plate Weldment
	F6707	Skid Plate Bundle
72	900712	Skid Pin (5/8" x 3")
73	86171	3/8" x 1 1/4" Hex Bolt (pl)
74	FX9102	Hand Crank Assembly (Complete Kit)
75	936402	PTO Safety Chain
76	909277	Manual Holder

**96" ALLIED SNOWBLOWER PTO
(Standard and Optional Long)**

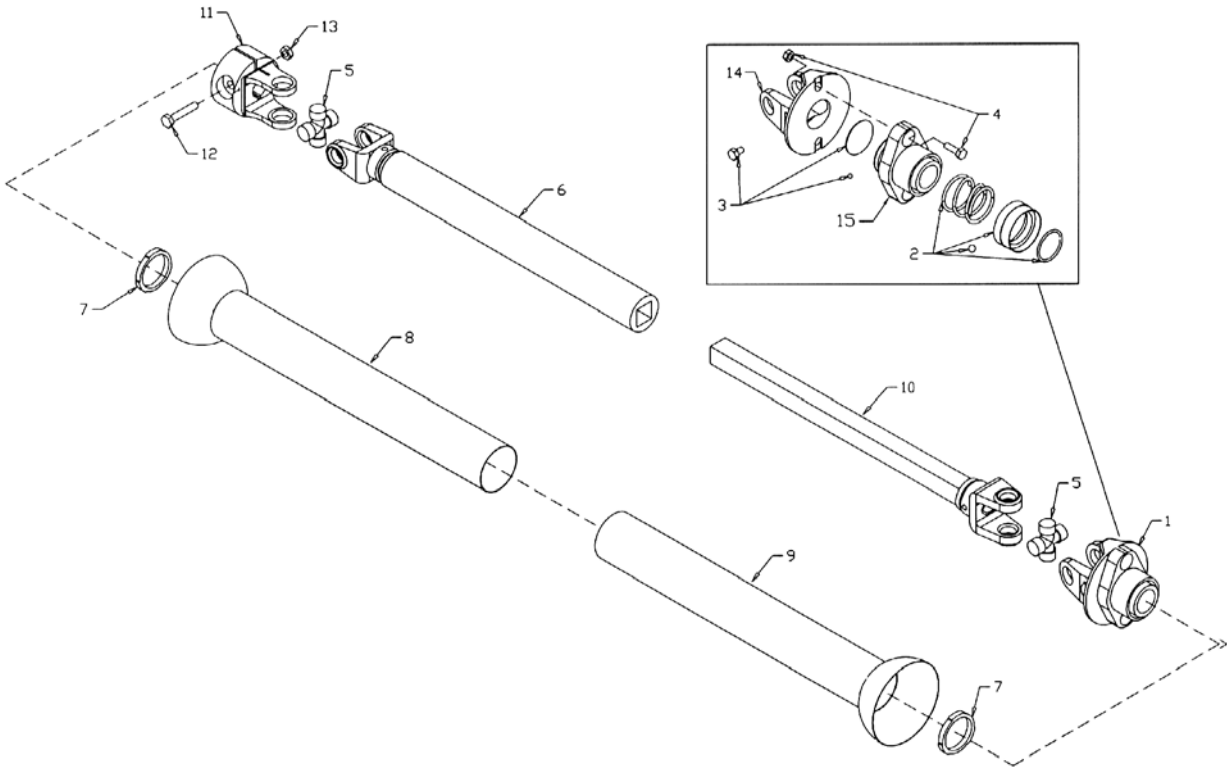

SB-24

96" ALLIED SNOWBLOWER PTO (Standard)

Item #	Part #	Description
	F0585	Shaft Complete
	907987	Tractor Half of PTO (Shear)
	907988	Implement Half of PTO (Clamp Yoke)
1	907989	Shear Assembly
2	936199	Safety Slide Lock Repair Kit (Collar, Spring, Ret. Ring, 2-Pawls)
3	936249	Shear Assembly Repair Kit (3/8" x 1/2" Bolt, Lube, Blank, 31-1/4" Balls)
4	903297	Shear Bolt - 5/16" x 1" (Grade 8) (Pack of 10)
5	936197	Repair Kit (Option)
	906548	Extended Life Repair Kit (Std.)
6	907994	Yoke & Tube
7	907991	Nylon Bearing
8	907993	Inner Shield
9	907992	Outer Shield
10	907990	Yoke & Shaft
11	907995	Clamp Yoke
12	81627	1/2" x 3" Hex Bolt (pl)
13	812364	1/2" Lock Nut (pl)
14	908002	Shear Yoke
15	936411	6 Spl. Shear Hub

96" ALLIED SNOWBLOWER PTO (Optional Long)

Item #	Part #	Description
	F0586	Shaft Complete
	907996	Tractor Half of PTO (Shear)
	907997	Implement Half of PTO (Clamp Yoke)
1	907989	Shear Assembly
2	936199	Safety Slide Lock Repair Kit (Collar, Spring, Ret. Ring, 2-Pawls)
3	936249	Shear Assembly Repair Kit (3/8" x 1/2" Bolt, Lube, Blank, 31-1/4" Balls)
4	903297	Shear Bolt - 5/16" x 1" (Grade 8) (Pack of 10)
5	936197	Repair Kit (Option)
	906548	Extended Life Repair Kit (Std.)
6	907998	Yoke & Tube
7	907991	Nylon Bearing
8	907999	Inner Shield
9	908000	Outer Shield
10	908001	Yoke & Shaft
11	907995	Clamp Yoke
12	81627	1/2" x 3" Hex Bolt (pl)
13	812364	1/2" Lock Nut (pl)
14	908002	Shear Yoke
15	936411	6 Spl. Shear Hub

96" ALLIED SNOWBLOWER GEARBOX

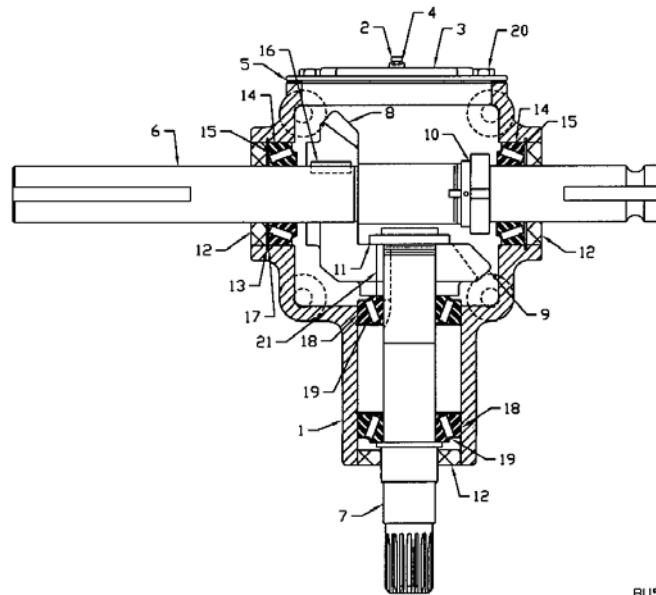

BU50505

960 FK, 85", & 96" ALLIED SNOWBLOWER GEARBOX PARTS LIST

Item #	Part #	Description
	BU50505	Gearbox Complete
1	BU50310	Gearbox Casting Only
2	BU500089-3	Pipe Plug
3	BU50457	Gearbox Cover
4	BU500167-1	Relief Valve
5	BU50458	Gearbox Gasket
6	BU50507	Cross Shaft
7	BU50502	Pinion Shaft
8	BU50329	Bevel Gear - 1 1/2" Bore
9	BU50331	Bevel Gear - 1 3/8" Bore
10	BU50428	Staking Lock Nut
11	BU50444	Staking Lock Nut
12	BU50422-1	Oil Seal (3 used)
13	BU50415	Retainer Ring (4 used)
14	BU575902	Bearing Cup (2 used)
15	BU575901	Bearing Cone (2 used)
16	BU50429	Key
17	BU50210X	Shim Set
18	BU575907	Bearing Cup (2 used)
19	BU575906	Bearing Cone (2 used)
20	BU500397-6	Hex Bolt 5/16" NC x 5/8" GR5 (pl)
21	BU50417-1	Key

3.5 x 8 CYLINDER ASSEMBLY

Item #	Part #	Description
	24803	Cyl Complete
1	24804	Tube Weldt
2	113934	Piston Rod 1.5 Dia
3	X2098	Seal Kit

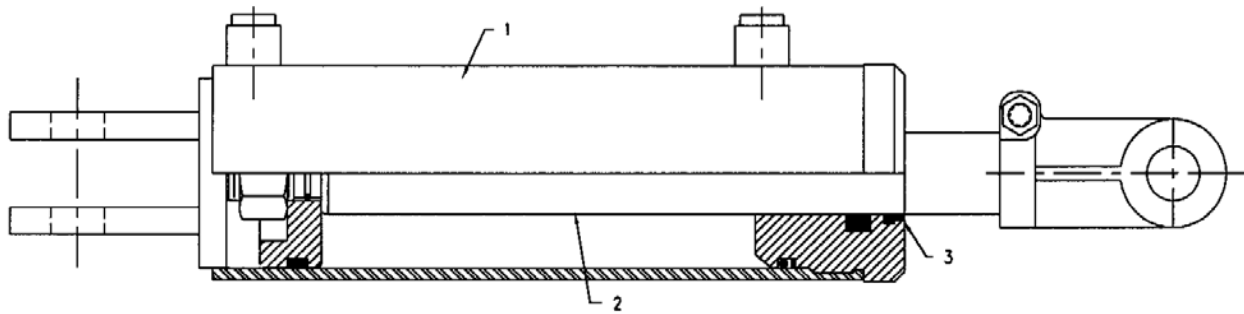

24803

1.75 X 5 CYLINDER ASSEMBLY

Item #	Part #	Description
	24930	Cyl Complete
1	115367	Tube Weldt
2	112104	Shaft Weldt 1.0 Dia
3	X2669	Seal Kit

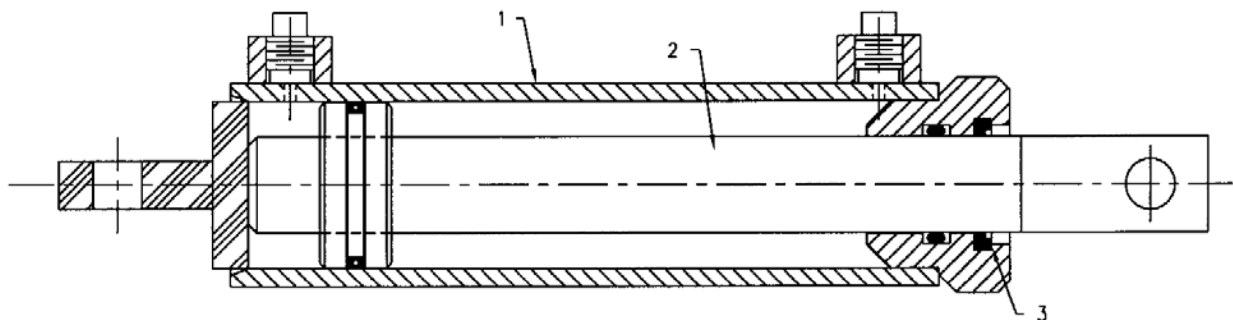

24930

SHIPPING KIT AND BUNDLE NUMBERS

The following is a list of kit numbers for this product and the bundle numbers, descriptions, and quantities for each kit.

QUANTITY	BUNDLE NO.	DESCRIPTION
YC9620Q 96" Allied Snowblower w/Hydraulic Chute Control & 3-Blade Fan		
1	F0624A	Body Assembly
1	FX9204	Quick Hitch
1	F9211	Spout Assembly
1	F0585	Standard PTO
YC9620Q-4 96" Allied Snowblower w/Hydraulic Chute Control & 4-Blade Fan		
1	FX9204	Quick Hitch
1	F0625A	Body Assembly
1	F9211	Spout Assembly
1	F0585	Standard PTO
YC9620QL 96" Allied Snowblower w/Hydraulic Chute Control, Long PTO & 3-Blade Fan		
1	F0624A	Body Assembly
1	FX9204	Quick Hitch
1	F9211	Spout Assembly
1	F0586	Long PTO
YC9620QL-4 96" Allied Snowblower w/Hydraulic Chute Control, Long PTO & 4-Blade Fan		
1	FX9204	Quick Hitch
1	F0625A	Body Assembly
1	F0586	Long PTO
1	F9211	Spout Assembly

OPTIONAL BUNDLE NUMBERS

The following is a list of options available for the Kits listed above.

- F0585 – Standard PTO
- F0586 – 36" PTO (optional long)
- FX9102 – Hand crank Kit
- FX9107 – Hydraulic Chute Control Kit
- F9116 – Hydraulic Cylinder & Hose Kit for Spout Swivel
- F9117 – Spout Deflector Cylinder & Hose Kit
- Y902 – Quick Hitch Kit

NOTES

NOTES

DIVISION LOCATIONS

Farm King Division
301 Mountain Street S.
Morden, MB R6M 1X7
Ph.: (204) 822-4467
Fax: (204) 822-6348

Allied/Inland Division
1260 Clarence Avenue
Winnipeg, MB R3T 1T2
Ph.: (204) 284-6100
Fax: (204) 477-2325

B.I.I. Division
1330 43rd Street N.W.
Fargo, ND 58102
Ph: (701) 282-7014
Fax: (701) 282-5865

U.S. WAREHOUSES

AR, West Memphis
(870) 732-3132

GA, Stone Mountain
(770) 908-9439

ID, Meridian
(208) 887-6006

IN, Clarksville
(812) 284-3376

KS, Wichita
(316) 265-9577

MN, Lakeville
(952) 469-5267

MT, Billings
(406) 248-7771

ND, Bismarck
(701) 223-1886

ND, Fargo
(701) 282-7003

NE, Blair
(402) 426-8211

OH, Youngstown
(330) 793-0862

OR, Beaverton
(503) 641-1865

SD, Huron
(605) 352-8616

TX, Houston
(713) 928-2632

UT, Salt Lake City
(801) 972-4321

WI, Portage
(608) 742-1370

CANADIAN WAREHOUSES

B.C., Abbotsford
(604) 864-2665

AB, Edmonton
(780) 962-6991

SK, Regina
(306) 781-2300

ON, Woodstock
(519) 539-0435

QC, Dorion
(450) 455-4840

OFFSHORE WAREHOUSES

Burando Hill
Katanning
W. Australia
011-618-98-214422

Chihuahua, Mexico
011-52-158-90306

John Kerr Equipment Ltd.
Wilcoxholm Farm
Linlithgow, W. Lothian
Scotland
011-441-506-842280

Skovde, Sweden
011-46-500-452651

Naestved, Denmark
011-45-557-29511

bühler

Buhler Manufacturing

**301 Mountain Street S.
Morden MB.
R6M 1X7
Ph.: (204) 822-4467
Fax: (204) 822-6348
www.buhler.com**