

# bühler

## farm king

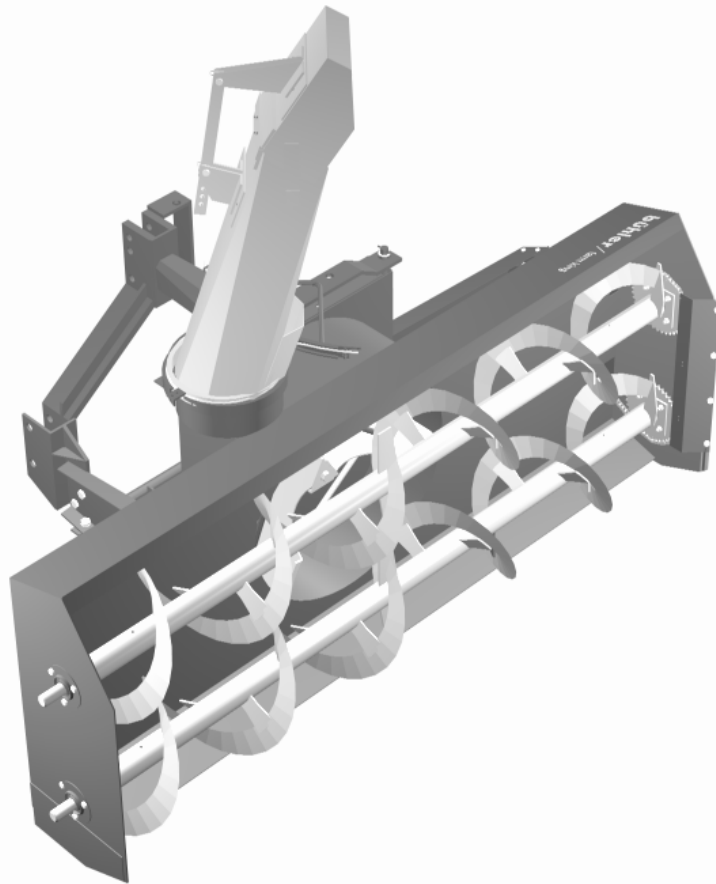

### #1080 Snowblower

Operator's and Parts Manual  
FK329

2008



**TABLE OF CONTENTS**

<b>DESCRIPTION</b>	<b>PAGE</b>
Warranty .....	1
Safety Instructions & Safety Sign Locations .....	2
Operating Instructions.....	3
Assembly Instructions.....	5
#1080 Farm King Snowblower Drawings.....	7
#1080 Farm King Snowblower Parts List.....	10
#1080 Farm King Snowblower PTO Drawing .....	14
#1080 Farm King Snowblower PTO Parts List.....	15
Shipping Kit and Bundle Numbers .....	16

## WARRANTY POLICY

Buhler Manufacturing products are warranted for a period of twelve (12) months (90 days for commercial application) from original date of purchase, by original purchaser, to be free from defects in material and workmanship under correct, normal agricultural use and proper applications.

Buhler Manufacturing's obligations under this warranty shall be limited to the repair or exchange, at Buhler Manufacturing's option, of any Buhler Manufacturing product or part which proves to be defective as provided. Buhler Manufacturing reserves the right to either inspect the product at the buyer's location or have it returned to the factory for inspection.

The above warranty does not extend to goods damaged or subject to accident, abuse or misuse after shipment from Buhler Manufacturing's factory, nor to goods altered or repaired by anyone other than an authorized Buhler Manufacturing representative.

Buhler Manufacturing makes no Express Warranties other than those, which are specifically described. Any description of goods, including any references and specifications in catalogues, circulars and other written material published, is for the sole purpose of identifying goods and shall conform to such descriptions. Any sample or model is for illustrative purposes only and does not create an Express Warranty that the goods conform to sample or model shown.

The purchaser is solely responsible for determining suitability of goods sold. This warranty is expressly in lieu of all other warranties expressed or implied. Buhler Manufacturing will in no event be liable for any incidental or consequential damages whatsoever. Nor for any sum in excess of the price received for the goods for which liability is claimed.

### **WARRANTY CLAIMS:**

Warranty requests must be prepared on Buhler Manufacturing Warranty Claim Forms with all requested information properly completed. Warranty Claims must be submitted within a thirty (30) day period from date of failure repair.

### **WARRANTY LABOR:**

Any labor subject to warranty **must** be authorized by Buhler Manufacturing. The labor rate for replacing defective parts, where applicable, will be credited at 100% of the dealer's posted shop rate. Defective parts will receive an extra 10% discount to assist with freight or other incidental costs.

### **GOVERNMENT LEGISLATION:**

Warranty terms and conditions are subject to Provincial or State legislation.

### **IMPORTANT FACTS:**

Buckets and Bucket Tines Carry No Warranty  
Bent Spears Carry No Warranty  
Snowblower Fan Shafts Carry No Warranty  
Mower Blades Carry No Warranty  
Portable Auger Parts Have Two (2) Year Warranty  
Loader Parts Have Two (2) Year Warranty

**IMPORTANT NOTE: This warranty does not apply to rentals**

**SNOWBLOWERS**

This manual is for model #1080 snowblowers with a combination three point and quick coupler hitch. All model #1080 snowblowers use an open gear drive. The standard model is a push type, which will mount to a tractor with 1000 rpm PTO only. This model uses a chain drive reducer in the welded gearbox assembly, which runs in an oil bath. A direct drive 540 RPM model is also available. It is supplied with category 2 pins as well as conversion bushings to category 3. This 108" wide snowblower comes with a hydraulic chute control as standard. A hand crank is not available. There is a shear bolt on the auger and two on the PTO shaft to protect the machine from damage if a large object is picked up. Any smaller objects in the snow will be thrown with it and could cause serious injury. Do not let anyone stand behind the tractor in the area of the discharged snow.

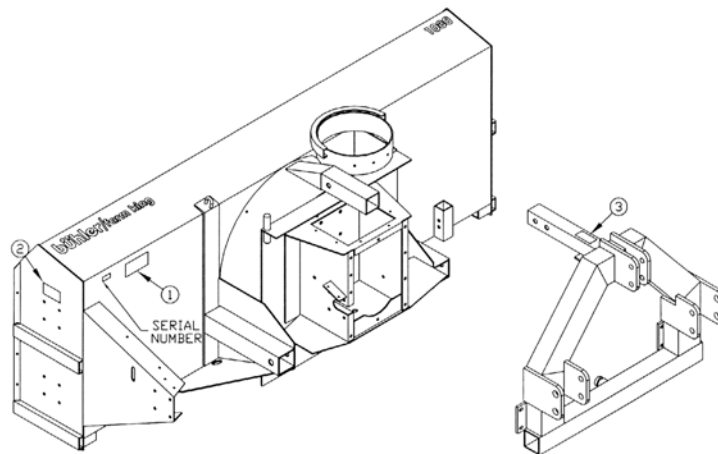

SB-31

 <span style="font-size: 2em; font-weight: bold;">CAUTION</span>
<ol style="list-style-type: none"> <li>1. Keep all shields in place.</li> <li>2. Disengage all power when servicing or unplugging machine.</li> <li>3. Keep hands and clothing away from all moving parts.</li> </ol>
963206

#1

Replace safety signs immediately should they become damaged, torn or illegible. Obtain replacements from your authorized dealer using the part numbers shown.

 <span style="font-size: 2em; font-weight: bold;">DANGER</span>
STAND CLEAR WHEN MACHINE IN OPERATION
102893

#2

 <span style="font-size: 2em; font-weight: bold;">WARNING</span>
CHECK PTO SHAFT LENGTH BEFORE RAISING OR LOWERING IMPLEMENT. SHAFT MUST NOT BOTTOM OR SEPERATE (SEE MANUAL)
108431

#3

## OPERATING INSTRUCTIONS

1. Do not operate the blower in the fully raised position. The three-point hitch on some tractors raises high enough to cause the PTO shaft to bind. This can cause damage to the PTO shaft and/or to the hitch and pins.
2. Depth of the cut can be partially controlled by tilting the blower forward or backward. Adjust the top link of the tractor hitch so the snowblower is just slightly tilted back when resting on the ground. **▲ CAUTION:** Excessive backward tilt may cause the “U” joints to flutter resulting in PTO shear bolt failure.
3. The snowblower hitch should mount on three types of tractor hitches. A standard category 2 uses the pins supplied without bushings. A standard category 3 uses the pins supplied with the bushings. A category 3 quick hitch uses the pins with bushings on the inside holds (holes are exactly 19” apart measured up and down.)
4. Adjust the lower link sway chains or blocks on the tractor to restrict movement of the blower when operating.
5. The snowblowers may be purchased with either of two available spouts. Both spouts have hydraulically controlled spout deflectors. The standard spout should be suitable for all general snow blowing applications. The truckloader spout was designed to blow directly onto the back of a truck. The maximum height of the truck side you blow over should be approximately 10 feet.
6. Run the blower at lot RPM to check operation before blowing snow.
7. The snowblower has shear bolts to protect the tractor and blower in case a large object enters the blower. The PTO shaft uses two - 3/8" x 1" (Grade 2) hex bolts as shear bolts. The auger uses one - 5/16" x 1 1/4" (Grade 5) hex bolt as a shear bolt. Shear bolts should be fastened with a lock nut. These bolts must be kept tight to prevent wear of the bolt and bolt holes.
8. Never run PTO shaft at over 1000 RPM.
9. Chain Tension: Slack on the lower side of the chain should be 3/8 to 1/2 inch.

**OPERATING INSTRUCTIONS – cont'd.**

## 10. Lubrication:

- a) The spout clamps and rings should be periodically lubricated with gun grease. This is particularly important on the truckloader spout which turns harder than the standard spout due to the length and weight.
- b) PTO shaft universal joints and splined slide should be greased daily.
- c) Regularly oiling the chain will significantly increase the life of the chain.
- d) The grease fitting on the hydraulic spout swivel arm and discharge spout should be kept lubricated.
- e) Use any 80-90 gear oil or multigrade with 80 minimum in the gearbox up to the level plug height.

11. Periodically check all bolts for tightness. The bolt holding on the fan and the bearing bolts are of particular importance.

12.  **DANGER: Always stop blowing for servicing or unplugging. The PTO should be disengaged before dismounting from the tractor.**

13. Shear Sprocket: The shear sprocket (#46) should be checked at the beginning of every season to make sure it will spin freely. Clean to loosen if necessary.

14. When replacing bearings or tightening a loose bearing collar, always tighten collar in the direction of shaft rotation using a center punch or a similar tool.

15.  **CAUTION:** Avoid raising or lowering snowblower under load. Doing so can create excessive end pressure on the PTO shaft which could lead to bearing failure on the snowblower.

## ASSEMBLY INSTRUCTIONS

1. Hitch Assembly: With lower hitch tubes (#3) turned as shown in drawing, slide them into the sleeves welded to the main body. These tubes are adjustable to two different positions. The correct position for each individual tractor will be determined when mounting the snowblower on the tractor (see Section 4). Start with the tubes pulled out to the last hole. These tubes are connected to the snowblower with a 1 ¼" x 5 ½" pin (#6) and a hairpin clip (#12). Slide the three-point hitch (#2) into the top sleeve on the snowblower body and hole in place with a 1" x 4 3/8" pin (#7) and a hairpin clip (#12). Bolt the bottom of the hitch to the ends of the hitch tubes using ½" x 2" hex bolts, lock washers, flat washers and hex nuts.
2. Spout Assembly: Mount the discharge spout (#64 or #73) using the spout clamp (#22) bolted to the spout ring on the snowblower. Lubricate the spout ring and clamp. Mount the 5" stroke cylinder (#68) on the spout as shown in the drawing.  
 **CAUTION:** The ports in the cylinder are both 9/16" orb. Be sure that the bottom edge of the deflectors are properly fitted in the guides before using the hydraulic control.
3. Hydraulic Spout Swivel:
  - a) Bolt the cylinder arm base (#17) to the bottom of the hitch using 5/8" x 2" hex bolts, lock washers and hex nuts. **NOTE:** There are three sets of holes. The hole used to bolt on this base must match with the holes used to assemble the hitch in the hitch tubes (i.e. 1<sup>st</sup> hole second hole, etc.)
  - b) Mount the spout swivel (#16) onto the swivel pin welded to the back corner of the fan housing using a 1 ¼" I.D. flat washer (#31) and a ¼" x 1 ¾" cotter pin (#32)
  - c) Wrap cable (#18) around spout and clamp to the ends of the swivel using 3/8" cable clamps (#19)
  - d) With the spout turned forward and the swivel arm centered with the spout, clamp the cable to the spout cable anchor using another cable clamp. Ensure that the spout is not jammed and that there is no slack in the cable.
  - e) Use a standard 8" stroke cylinder (20 ¼" min., 28 ½" max. pin centers).

**ASSEMBLY INSTRUCTIONS - Cont'd.**

## 4. Mounting blower on Tractor:

- a) Mount the blower on a tractor with a category 2 or 3 standard hitch or a category 3 quick hitch. The hitch has two holes both at the top of the hitch and at each lift arm. When using a quick hitch, the pins must be in the inside set of holes. Use the outside set of holes with a standard three-point hitch. The lift arm pins also have a narrow spacing for category 2 and a wide spacing for category 3.
- b) Using tape or a bright colored marking pen, mark on the outer shields of the PTO the position where the shaft is completely pushed together and the position where you have a 4" overlap. Watch these marks when moving the blower through all possible operating angles to see that the PTO shaft stays within this range. Slide the hitch in if necessary to keep the PTO shaft in this operating range. Do not forget to change the position of the cylinder arm (#17) by the same distance that you move the hitch.
- c) With the engine on the tractor shut off, attach the PTO shaft. The tractor end has a 1 3/8" 21 spline end with a spring loaded locking collar. The snowblower end has a clamp style yoke with a 3/8" keyway. Slide the yoke onto the 1 3/4" jackshaft with the 3/8" key supplied. Lock the yoke in place with the 5/8" x 3 1/4" bolt and lock nut fitted through the groove in the gearbox shaft. After tightening the bolt, insert and tighten the 3/8" socket set screw supplied.
- d) Always check to see that both ends of the PTO shaft are securely attached every time the snowblower is used. This should always be done with the tractor engine off.



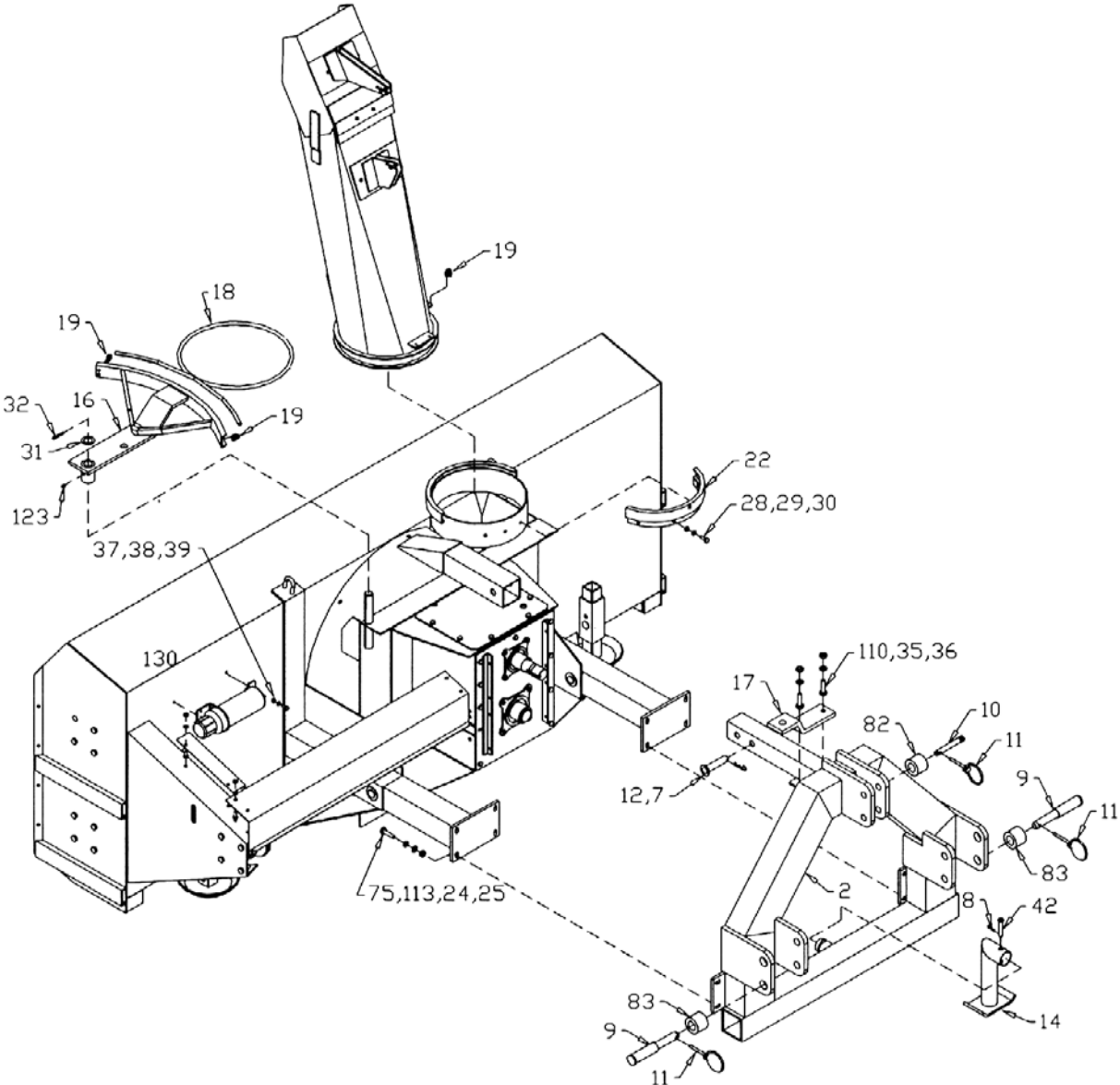

SB-28

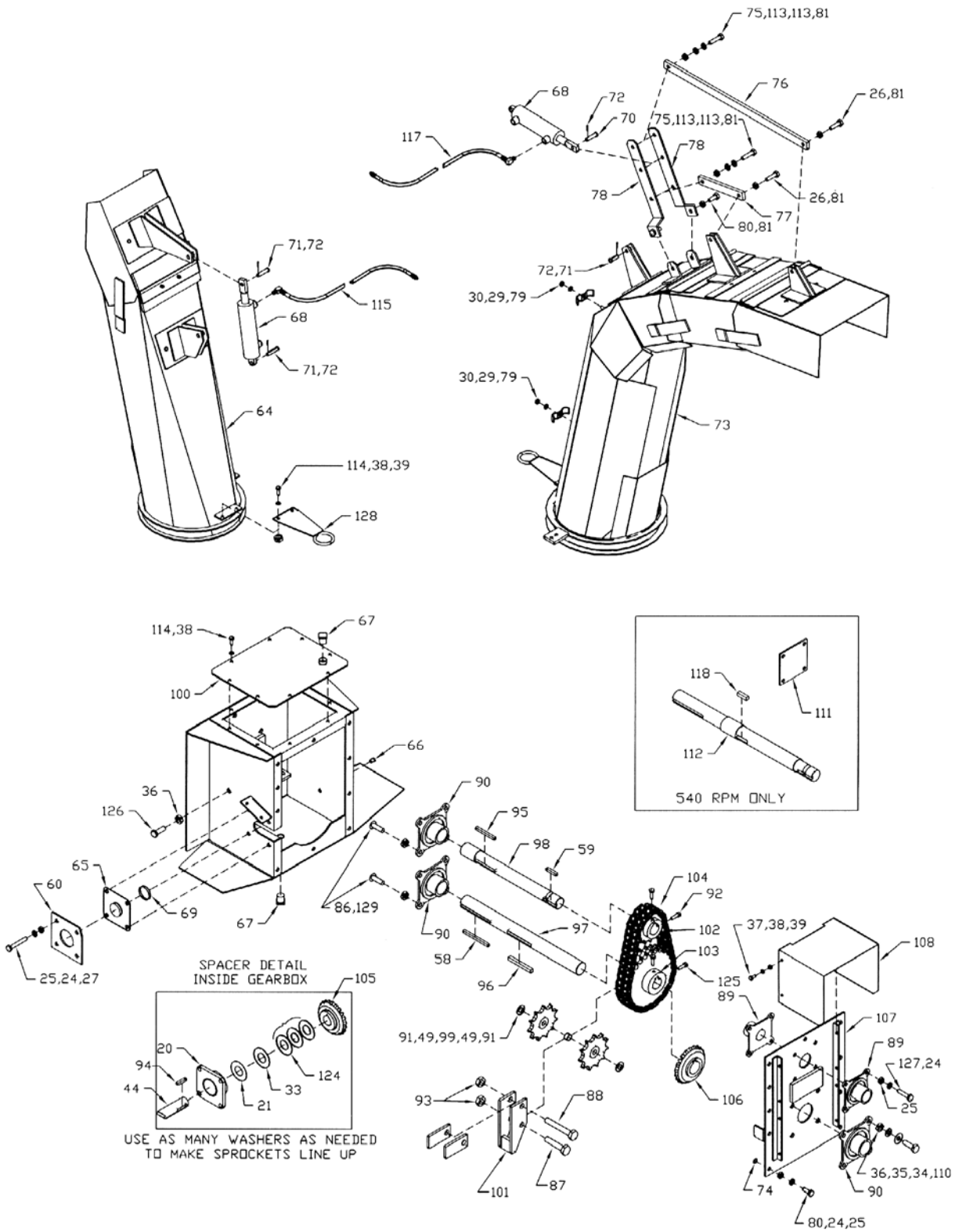

SB-29

## WHEN ORDERING PARTS

Always give your dealer the Model, Color, and Serial Number of your machine to assist him in ordering and obtaining the correct parts. Use the exploded view and tabular listing of the area of interest to exactly identify the required part.

### #1080 Snowblower

Item #	Part #	Description
1	906491	Main Body Weldment
2	F9244	3-point Hitch Weldment (902129)
3	965307	Lower Hitch Tube (4"SQ. X 29 1/2")
4	902407	Skid Plate Weldment
	F6707	Skid Plate Bundle
5	900712	Skid Pin
6	965205	Lower Hitch Tube Pin (1 1/4" X 5 1/2")
7	965206	Upper Hitch Tube Pin (1" X 4 3/8")
8	961012	#16 Hair Pin Clip
9	967461	Lift Pin Cat 2-3
10	965910	Top Lift Pin (Cat.2)
11	965911	7/16" Linch Pin
12	12779	#9 Hair Pin Clip
13	965209	Cutting Edge
14	965308	Jack Stand
15	965211	Chain Guard
16	965302	Hydraulic Swivel Arm
17	965213	Cylinder Arm Base
18	965654	3/8" X 80" Cable
19	964264	3/8" Cable Clamp
20	968632	1 1/2" Housing W/ Bearing - 4 Bolt
21	9812443	1 1/2" x 18GA Narrow Rim Washer
22	965215	Spout Clamp
23	967475	1/2" X 1 3/4" Fl Hd Bolt (skt) (pl)
24	81637	1/2" Lock Washer (pl)
25	81636	1/2" Hex Nut (pl)
26	87553	1/2" X 1 3/4" Hex Bolt (pl)
27	81628	1/2" X 3 1/4" Hex Bolt (pl)
28	86170	3/8" X 1" Hex Bolt (pl)
29	81593	3/8" Lock Washer (pl)
30	81592	3/8" Hex Nut (pl)
31	9812487	1 1/4" x 10GA Narrow Rim Washer (pl)
32	81210	1/4" X 2" Cotter Pin (pl)
33	9812444	1 1/2" x 14GA Narrow Rim Washer
34	81678	5/8" BS Flat Washer (pl)

35	81677	5/8" Lock Washer (pl)
36	81676	5/8" Hex Nut (pl)
37	81549	5/16" X 3/4" Hex Bolt (pl)
38	81569	5/16" Lock Washer (pl)
39	81568	5/16" Hex Nut (pl)
40	965216	Auger (15" O.D. X 107 3/8" Long)
41	902902	4-Blade Fan Weldment
42	965294	Jack Stand Pin
43	F9231	Standard PTO (1 3/8" X 21 spline)
	F9232	Optional PTO (1 3/4" X 20 spline)
	F9233	540 RPM PTO (1 3/8" X 6 spline)
44	965280	Drive Shaft
45	965281	Drive Shaft Guard
46	965221	Shear Sprocket (13T, #80)
47	965222	Flighting Sprocket (40T, #80)
48	965282	Roller Chain (#80 X 109 link w/ Connctor & Offset)
	965273	#80 Offset Link only
49	965224	Idler Sprocket (11T, #80, 3/4" bore)
50	965225	Idler Spacer (1 1/4" O.D. X 3/4" I.D. X 2 5/16"Lg)
51	811751	3/4" X 5" Hex Bolt (pl)
52	81702	3/4" B.S. Flat Washer (pl)
53	81701	3/4" Lock Washer (pl)
54	81700	3/4" Hex Nut (pl)
55	81552	5/16" X 1 1/4" GR. 5 Hex Bolt (pl)
56	812362	5/16" Lock Nut (pl)
57	811792	3/8" X 1 1/2" Hex Bolt (pl)
58	965226	Fan Key (3/8" X 3/8" X 5")
59	968807	PTO Key (3/8" X 3/8" X 2")
60	965296	Bearing Spacer
61	963030	1/2" X 3" Sq. Hd. Set Screw (pl)
62	984077	1/2" Jam Nut (pl)
63	84270	5/8" X 1 3/4" Hex Bolt (pl)
64	F9241	Standard Spout Weldment
65	965647	1 1/2" Oil Seal Plate
66	967451	1/2" Solid Pipe Plug
67	967452	1" Solid Pipe Plug
68	24930	Cylinder 1.75DIA X 5.0 - 9/16" ORB
69	967453	Oil Seal (CR #15142)
70	960913	1/2" X 1 13/16" Clevis Pin (pl)
71	961876	1/2" X 1 1/2" Clevis Pin (pl)
72	9812430	1/8" X 1" Cotter Pin (pl)
73	F9243	Truckloader Spout Assembly 10' (965306 - Weldment)
	F9234	Truckloader Spout Assembly 7' (965309 - Weldment)
74	82111	#111 O-Ring

75	811791	1/2" X 2" Hex Bolt (pl)
76	965304	Spout Link - 28 1/8"
77	965305	Spout Link - 8 3/4"
78	965238	Cylinder Arm
79	965239	Hose Clamp
80	81620	1/2" X 1 1/4" Hex Bolt (pl)
81	812364	1/2" Lock Nut (pl)
82	965266	CAT. 2-3 Top Link Pin Bushing
83	965267	CAT. 2-3 Lift Arm Bushing
84	965268	Fan Housing Liner
85	967431	3/8" X 1" Flat Head Bolt (pl)
86	905609	5/8" X 2 1/4" Flat Head Bolt (pl)
87	810149	3/4" X 3 1/2" Hex Bolt (pl)
88	905630	3/4" X 5" Idler Bolt
89	906497	1 3/4" Housing w/ bearing (Ductile)
	965283	1 3/4" Bearing w/ collar
	906498	1 3/4" Ductile Housing Only
90	906499	2" Housing w/bearing (Ductile)
	967375	2" Bearing w/collar
	906500	2" Ductile Housing Only
91	84050	3/4" S.A.E. Flat Washer (pl)
92	985639	3/8"Dia x 1/2" Socket Set Screw
93	812365	3/4" Lock Nut (pl)
94	965821	3/8" x 1 3/4" Key
95	965284	3/8" x 3 3/4" Key
96	965285	1/2" x 4 1/2" Key
97	965286	Fan Shaft (2" x 23")
98	965667	Jack Shaft (2"/1 3/4" x 18 3/4")
99	965288	Idler Sprocket Spacer
100	965660	Gearbox Cover
101	965290	Chain Tightener Weldment
102	965269	Sprocket 15T, #80 DBL, 1 3/4" B
103	965270	Sprocket 28T, #80 DBL, 2" B
104	965271	Chain (#80 Dbl x 40 link w/ Connector)
105	965275	Gear 22T, 1 1/2" Bore
106	965274	Gear 22T, 2" Bore
107	906496	Gearbox Front Cover Plate
108	965655	PTO Guard
109	965295	Idler Shield
110	84299	5/8" x 2" Hex Bolt (pl)
111	965298	1 3/4" Bearing Cover (540 RPM only)
112	965299	540 RPM Fan Shaft
113	81638	1/2" BS Flat Washer (pl)
114	812026	5/16" x 1" Hex Bolt (pl)

---

115	115370	3/8" x 114" Hose w/90 Degree Elbow
116	905080	Idler Assembly - Parts Only
117	115371	3/8" x 156" Hose w/fittings
	115369	3/8 x 156 Hose 1/2 MNPT x 9/16 SWFJIC
	811918	Elbow 90deg 9/16 SWMORB x 9/16 MJIC
	886786	Elbow 90deg 1/4" MNPT x 9/16" MJIC
118	902127	1/2" x 1 3/4" Gear Key (540 RPM)
119	936402	PTO Safety Chain
120	967433	5/8" x 3 1/4" Hex Bolt (pl)
121	812482	5/8" Lock Nut (pl)
122	84277	1/2" x 1 1/2" Hex Bolt (pl)
123	967164	Pound-In Grease Fitting
124	967135	1 1/2" x 10GA Narrow Rim Washer (pl)
125	967464	3/8" x 1 1/4" Sq Hd Set Screw
126	84270	5/8" x 1 3/4" Hex Bolt (pl) (540 RPM)
	968898	5/8" x 4" Sq Hd Set Screw (1000 RPM)
127	81624	1/2" x 2 1/4" Hex Bolt (pl)
128	907590	Spout Hose Holder
129	812482	5/8" Lock Nut (pl)
130	909277	Manual Holder

#1080 SNOWBLOWER PTO

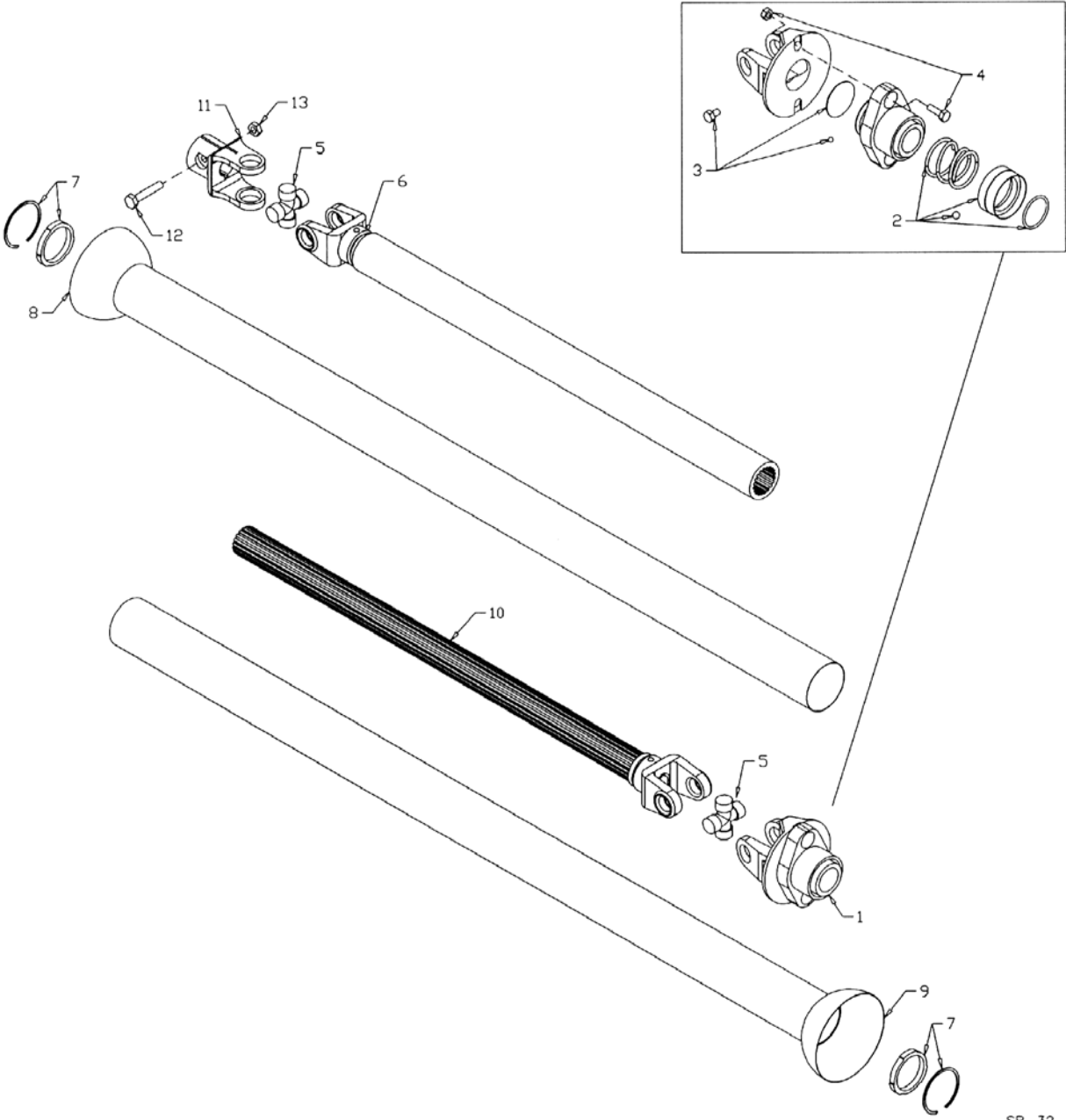

SB-32

**108" SNOWBLOWER PTO SHAFT PARTS LIST**

<b>Item #</b>	<b>Part #</b>	<b>Description</b>
	F9231	Standard Shaft (21 Spline, 1 3/8") - 1000 RPM
	F9232	Optional Shaft (20 Spline, 1 3/4") - 1000 RPM
	F9233	540 RPM Shaft (6 Spline, 1 3/8")
1	936413	Standard Shear Assembly (21 Spl, 1 3/8")
	936422	Shear Hub Only (21 Spl, 1 3/8")
	936414	Optional Shear Assembly (20 Spl, 1 3/4")
	936423	Shear Hub Only (20 Spl, 1 3/4")
	936429	540 RPM Shear Assy (6 Spl, 1 3/8")
	936424	Shear Hub Only (6 Spl, 1 3/8")
	936428	Shear Yoke Only (All Sizes)
2	936415	Safety Slide Lock Repair Kit (20 Spl, 1 3/4")
	936199	Safety Slide Lock Repair Kit (7 & 21 Spl, 1 3/8")
3	936249	Shear Assy Repair Kit
4	908890	Shear Bolt - 3/8" x 1" (Gr.2) - 1000 RPM (Pack of 10)
	908846	Shear Bolt - 3/8" x 1" (Gr.8) - 540 RPM (Pack of 10)
5	936197	Repair Kit (Option)
	906548	Extended Life Repair Kit (Std)
6	936426	Yoke & Tube (Splined)
7	936417	Bearing & Snap Ring Kit
8	936418	Inner Guard
9	936419	Outer Guard
10	936425	Yoke & Shaft (Splined)
11	936421	Clamp Yoke
12	967433	5/8" x 3 1/4" Bolt
13	812482	5/8" Lock Nut

**SHIPPING KIT AND BUNDLE NUMBERS**

The following is a list of kit numbers for this product and the bundle numbers, descriptions, and quantities for each kit.

	<b>QUANTITY</b>	<b>BUNDLE NO.</b>	<b>DESCRIPTION</b>
<b>Y1080C</b>	<b>1000 RPM WITH STANDARD SPOUT</b>		
	1	F9244	Hitch
	1	F9241	Standard Spout
	1	F0198	Body Assembly
	1	F0560	Deflector Cylinder & Hose Kit
	1	F9231	PTO 1000 rpm (1 3/8" x 21 spline)
<b>Y1080CT</b>	<b>1000 RPM WITH TRUCKLOADER SPOUT</b>		
	1	F9244	Hitch
	1	F9243	10' Truckloader Spout
	1	F0198	Body Assembly
	1	F9118	Deflector Cylinder & Hose Kit
	1	F9231	PTO 1000 rpm (1 3/8" x 21 spline)
<b>Y1080D</b>	<b>540 RPM WITH STANDARD SPOUT</b>		
	1	F9244	Hitch
	1	F9241	Standard Spout
	1	F0200	Body Assembly
	1	F0560	Deflector Cylinder & Hose Kit
	1	F9233	PTO 540 rpm (1 3/8" x 6 spline)
<b>Y1080DT</b>	<b>540 RPM WITH TRUCKLOADER SPOUT</b>		
	1	F9244	Hitch
	1	F9243	Truckloader Spout
	1	F0200	Body Assembly
	1	F9118	Deflector Cylinder & Hose Kit
	1	F9233	PTO 540 rpm (1 3/8" x 6 spline)

**OPTIONAL BUNDLE NUMBERS:**

The following is a list of options available for the Kits listed above.

F9116	Swivel Arm Cylinder & Hose Kit
F9232	1000 rpm PTO (1 3/4" x 20 spline)
F9233	540 rpm PTO (1 3/8" x 6 spline)
Y907	7' Truckloader Spout - c/w Cylinder & Hoses
Y910	10' Truckloader Spout - c/w Cylinder & Hoses

## NOTES

## NOTES

## NOTES



## DIVISION LOCATIONS

Farm King Division  
301 Mountain Street S.  
Morden, MB R6M 1X7  
Ph.: (204) 822-4467  
Fax: (204) 822-6348

Allied/Inland Division  
1260 Clarence Avenue  
Winnipeg, MB R3T 1T2  
Ph.: (204) 284-6100  
Fax: (204) 477-2325

B.I.I. Division  
1330 43<sup>rd</sup> Street N.W.  
Fargo, ND 58102  
Ph: (701) 282-7014  
Fax: (701) 282-5865

## U.S. WAREHOUSES

AR, West Memphis  
(870) 732-3132

GA, Stone Mountain  
(770) 908-9439

ID, Meridian  
(208) 887-6006

IN, Clarksville  
(812) 284-3376

KS, Wichita  
(316) 265-9577

MN, Lakeville  
(952) 469-5267

MT, Billings  
(406) 248-7771

ND, Bismarck  
(701) 223-1886

ND, Fargo  
(701) 282-7003

NE, Blair  
(402) 426-8211

OH, Youngstown  
(330) 793-0862

OR, Beaverton  
(503) 641-1865

SD, Huron  
(605) 352-8616

TX, Houston  
(713) 928-2632

UT, Salt Lake City  
(801) 972-4321

WI, Portage  
(608) 742-1370

## CANADIAN WAREHOUSES

B.C., Abbotsford  
(604) 864-2665

AB, Edmonton  
(780) 962-6991

SK, Regina  
(306) 781-2300

ON, Woodstock  
(519) 539-0435

QC, Dorion  
(450) 455-4840

## OFFSHORE WAREHOUSES

Burando Hill  
Katanning  
W. Australia  
011-618-98-214422

Chihuahua, Mexico  
011-52-158-90306

John Kerr Equipment Ltd.  
Wilcoxholm Farm  
Linlithgow, W. Lothian  
Scotland  
011-441-506-842280

Skovde, Sweden  
011-46-500-452651

Naestved, Denmark  
011-45-557-29511

# bühler

**Buhler Manufacturing**

**301 Mountain Street S.  
Morden MB.  
R6M 1X7  
Ph.: (204) 822-4467  
Fax: (204) 822-6348  
[www.buhler.com](http://www.buhler.com)**