

bühler

farm king

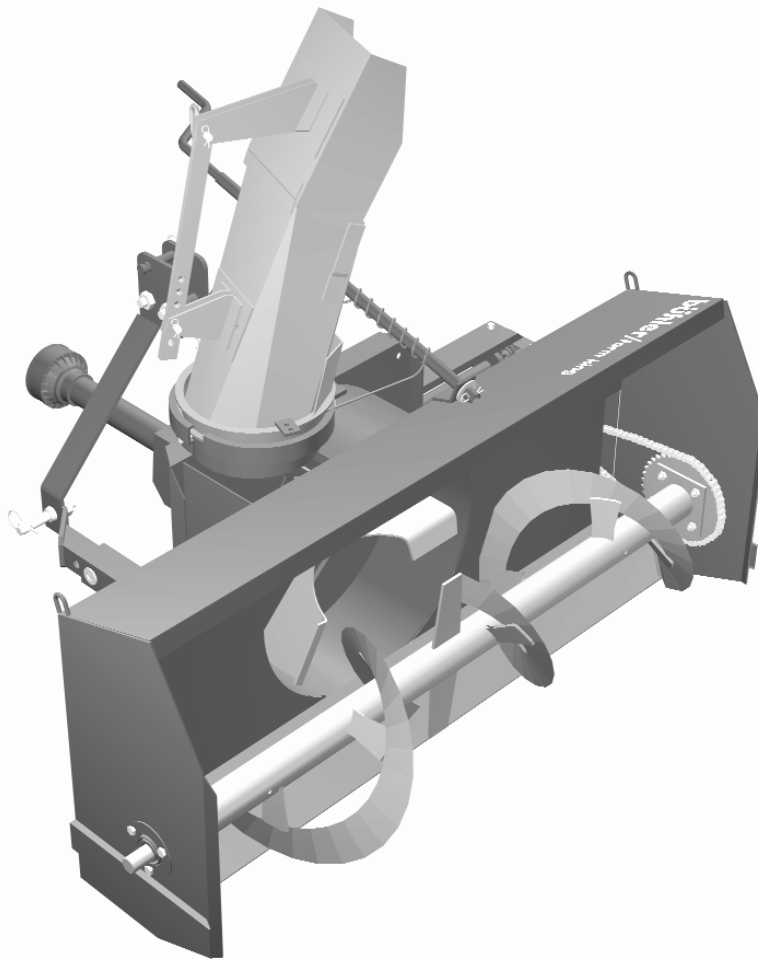

500 & 600 Snowblowers

Operator's and Parts Manual
FK311

2006

TABLE OF CONTENTS

DESCRIPTION	PAGE
Warranty	1
Safety Instructions & Safety Sign Locations	2
Operating Instructions	3
Assembly Instructions	5
500 & 600 Snowblower Drawings	8
500 & 600 Snowblower Parts List	10
500 & 600 Snowblower PTO Drawing.....	13
500 & 600 Snowblower PTO Parts Lists	14
Cylinder Assembly Drawings & Parts Lists	15
Shipping Bundles	16

WARRANTY POLICY

Buhler Manufacturing products are warranted for a period of twelve (12) months (90 days for commercial application) from original date of purchase, by original purchaser, to be free from defects in material and workmanship under correct, normal agricultural use and proper applications.

Buhler Manufacturing's obligations under this warranty shall be limited to the repair or exchange, at Buhler Manufacturing's option, of any Buhler Manufacturing product or part which proves to be defective as provided. Buhler Manufacturing reserves the right to either inspect the product at the buyer's location or have it returned to the factory for inspection.

The above warranty does not extend to goods damaged or subject to accident, abuse or misuse after shipment from Buhler Manufacturing's factory, nor to goods altered or repaired by anyone other than an authorized Buhler Manufacturing representative.

Buhler Manufacturing makes no Express Warranties other than those, which are specifically described. Any description of goods, including any references and specifications in catalogues, circulars and other written material published, is for the sole purpose of identifying goods and shall conform to such descriptions. Any sample or model is for illustrative purposes only and does not create an Express Warranty that the goods conform to sample or model shown.

The purchaser is solely responsible for determining suitability of goods sold. This warranty is expressly in lieu of all other warranties expressed or implied. Buhler Manufacturing will in no event be liable for any incidental or consequential damages whatsoever. Nor for any sum in excess of the price received for the goods for which liability is claimed.

WARRANTY CLAIMS:

Warranty requests must be prepared on Buhler Manufacturing Warranty Claim Forms with all requested information properly completed. Warranty Claims must be submitted within a thirty (30) day period from date of failure repair.

WARRANTY LABOR:

Any labor subject to warranty **must** be authorized by Buhler Manufacturing. The labor rate for replacing defective parts, where applicable, will be credited at 100% of the dealer's posted shop rate. Defective parts will receive an extra 10% discount to assist with freight or other incidental costs.

GOVERNMENT LEGISLATION:

Warranty terms and conditions are subject to Provincial or State legislation.

IMPORTANT FACTS:

Buckets and Bucket Tines Carry No Warranty
Bent Spears Carry No Warranty
Snowblower Fan Shafts Carry No Warranty
Mower Blades Carry No Warranty
Portable Auger Parts Have Two (2) Year Warranty
Loader Parts Have Two (2) Year Warranty

IMPORTANT NOTE: This warranty does not apply to rentals

SNOWBLOWER

This manual is for both models #500 and #600 snowblowers. When ordering parts, specify model number and serial number. Both snowblowers are the push type and will mount to a tractor with a category 1 three-point hitch or a category 1 Quick Hitch and 540 rpm PTO. The #500 has a 50" cutting width while the #600 has a 60" cutting width. Both snowblowers come with a hand crank chute control as standard. A hydraulic control is available as an option at extra cost. There is a shear bolt on the auger and on the PTO shaft to protect the machine from damage if a large object is picked up. Any smaller objects in the snow will be thrown with it and could cause serious injury. Do not let anyone stand behind the tractor in the area of the discharged snow.

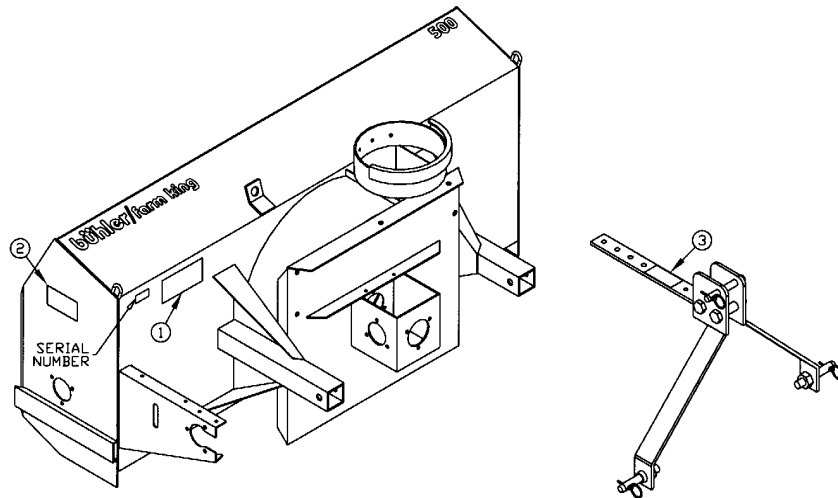

SB-04

 <h3>CAUTION</h3>
<ol style="list-style-type: none"> 1. Keep all shields in place. 2. Disengage all power when servicing or unplugging machine. 3. Keep hands and clothing away from all moving parts.
<small>963206</small>

#1

 <h3>DANGER</h3>
<p>STAND CLEAR WHEN MACHINE IN OPERATION</p>
<small>102893</small>

#2



 <h3>WARNING</h3>
<p>CHECK PTO SHAFT LENGTH BEFORE RAISING OR LOWERING IMPLEMENT. SHAFT MUST NOT BOTTOM OR SEPERATE (SEE MANUAL)</p>
<small>108431</small>

#3

OPERATING INSTRUCTIONS

1. Do not operate the blower in the fully raised position. The three-point hitch on some tractors raises high enough to cause the PTO shaft to bind. This can cause damage to the PTO shaft and/or to the hitch and pins.
NOTE: PTO shaft angle should not exceed 20° for optimum performance and life. Damage may occur to PTO and/or snowblower if angle becomes more extreme.
2. Depth of cut can be partially controlled by tilting the blower forward or backward. Adjust the top link of the tractor hitch so the snowblower is just slightly tilted back when resting on the ground.
 **ALERT:** Excessive backward tilt may cause the “U” joints to flutter resulting in PTO shear bolt failure.
3. Adjust the lower link sway chains or blocks on the tractor to restrict side movement of the blower when operating.
4. Run the blower at low rpm to check operation before blowing snow.
5. The snowblower has two shear bolts to protect the tractor and blower in case a large object enters the blower. PTO shear bolts - #500 - one 3/8" x 1" (gr.8), #600 - two 5/16" x 1" (gr. 8), auger shear bolt – 1/4" x 1" (gr.2). Shear bolts should be fastened with a lock nut or two jam nuts. These bolts must be kept tight to prevent wear of the bolt and bolt holes.
6. Never run PTO shaft at over 600 rpm.
7. Chain Tension: Slack on the lower side of the chain should be 3/8 to 1/2"
8. Lubrication:
 - a) The spout clamps and rings should be periodically lubricated with gun grease.
 - b) PTO shaft universal joints and square shaft slide should be greased daily.
 - c) PTO shear yoke should be greased before using the blower for the first time.
 - d) Regularly oiling the chain will significantly increase the life of the chain.
 - e) Gearbox is open type and need not be greased or lubricated.
 - f) Hydraulic spout option – grease the swivel arm.

OPERATING INSTRUCTIONS – cont'd.

9. Periodically check all bolts for tightness. The bolt holding on the fan and the bearing bolts are of particular importance.
10.  **Danger:** Always stop blower for servicing or unplugging. The PTO should be disengaged before dismounting from the tractor.
11.  **Caution:** Always check to see that both ends of the PTO shaft are securely attached as per instructions every time you are preparing to use the snowblower.
12. When replacing bearings or tightening a loose bearing collar, always tighten collar in the direction of shaft rotation using a center punch or a similar tool.
13. Shear Sprocket: The shear sprocket (#43) should be checked at the beginning of every season to make sure it will spin freely. With time the sprocket plate could corrode and seize which will not allow the shear bolt to break if something jams in the snowblower auger. Clean to loosen if necessary.

#500 AND #600 SNOWBLOWER ASSEMBLY INSTRUCTIONS

1. Mount the discharge spout (#2) using the spout clamp (#3) bolted to the spout ring on the snowblower. Lubricate the spout ring and clamp.
NOTE: A hydraulic cylinder and hose kit to control the spout deflector is available as an option.

2. **Hitch Assembly:** With right and left hitch tubes (#5 & #6) turned as shown in drawing, slide them into the sleeve welded to the main body. These tubes are adjustable to four different positions. The correct position for each individual tractor will be determined when mounting the snowblower on the tractor. These tubes are connected to the snowblower with a $\frac{3}{4}$ " x $3\frac{1}{4}$ " pin (#11) and a hair pin clip (#12). Bolt the left (#84) and the right (#85) hitch arms to the outside of the clevises on the hitch tubes using the lift pins (#9). **NOTE:** Pins should be turned to the outside. Do not tighten any hardware until assembly is complete. Join the top of the hitch arms by bolting a 1" O.D. x $2\frac{1}{4}$ " spacer (#4) between the top plates using a $\frac{3}{4}$ " x 4" bolt and lock nut through the lower outside holes. Bolt the hitch top bar (#86) between the same plates using the same bolt through the welded tube on the bar. Use the inside holes on the top plates for the top bar. The other end of the hitch top bar bolts to the top of the blower fan housing with a $\frac{1}{2}$ " x $1\frac{3}{4}$ " hex bolt, lock washer and hex nut. Use the same hole position as the hitch tubes. Tighten all hardware.

A category 1 top link pin (#8) is fitted in the top holes of the hitch arm plates. This pin is used for standard three-point hitch only. The bushing in the lower holes is used for the Quick Hitch.

3. **Hand Crank Assembly:** (Standard)
 - a) Bolt the crank mounting bracket (#16) to the top of the hitch using $\frac{3}{8}$ " x $1\frac{1}{4}$ " hex bolts, lock washers and hex nuts.
 - b) Insert the crank tube (#15) through the mount and through the bracket welded to the main housing. Lock the crank in place using a washer and roll pin on each side of the bracket.
 - c) Thread the cable (#17) through the hole in the crank tube to even lengths and wrap around the tube to each side of the hole four turns in opposite directions.
 - d) With the spout turned forward, fasten the cable to the bracket welded to the bottom of the spout using a $\frac{1}{4}$ " cable clamp (#70).

500 & 600 SNOWBLOWER ASSEMBLY INSTRUCTIONS – cont'd.

4. **Hydraulic Control Assembly:** (Option)
 - a) Bolt the hydraulic swivel assembly (#21) to the back of the fan housing on the left side using ½" x 1 ¼" hex bolts, lock washers and hex nuts.
 - b) Bolt the cylinder mounting bracket (#23) to the back of the fan housing on the right side using the same size hex bolts.
 - c) Turn the spout forward and the center of the swivel arm in line with the spout center. With the spout and swivel arm in this position, wrap the cable (#22) around the spout and clamp to both ends of the swivel arm and to the bracket welded to the bottom of the spout using 3/16" cable clamps (#20).
 - d) Use a standard 8" stroke cylinder (20 ¼" min., 28 ¼" max. pin centers).

5. **Mounting Blower on Tractor:**
 - a) Mount the blower on a tractor with a category 1 hitch.
 - b) Using tape or a bright colored marking pen, mark on the outer shield the position where the shaft is completely pushed together and the position where you have a 4" overlap. Watch these marks when moving the blower through all possible operating angles to see that the PTO shaft stays within this range.
 - c) With the engine on the tractor shut off, attach the PTO shaft. The tractor end has a standard 6-spline end with a spring loaded locking collar. The snowblower end has a clamp-style yoke with a ¼" key way. Slide the yoke onto the gearbox shaft with the ¼" key supplied. Lock the yoke in place with the ½" x 3" hex bolt and lock nut fitted through the groove in the gearbox shaft. After tightening the bolt, insert and tighten the 3/8" socket set screw supplied. **⚠ Caution:** Always check to see that both ends of the PTO shaft are securely attached every time the snowblower is used. This should always be done with the tractor engine off.
 - d) Check that the PTO shaft does not bottom or separate with the blower in the extreme high and low positions. Check to see which of the four different hitch positions will allow you to keep about a 4" minimum overlap on the PTO shields without bottoming out. This position varies between different tractor models because of the different lengths of the three-point arms. If the PTO shaft is still too long with the hitch fully extended, the PTO shaft will have to be cut shorter. Check for free movement of all parts in various raised positions, particularly the PTO shaft.

500 & 600 SNOWBLOWER ASSEMBLY INSTRUCTIONS – cont'd.**6. PTO Shield:**

All snowblowers manufactured for the 1990 production and up are supplied with a PTO shield. The PTO shield (#65) bolts to the gearbox assembly using $\frac{1}{4}$ " x $\frac{3}{4}$ " hex bolts. Hook one end of the spring (#66) in the hole in the back edge of the PTO shield and the other end of the spring in the hole punched in the edge of the gearbox assembly.

 **CAUTION:** Do not run the snowblower without the PTO shield in place.

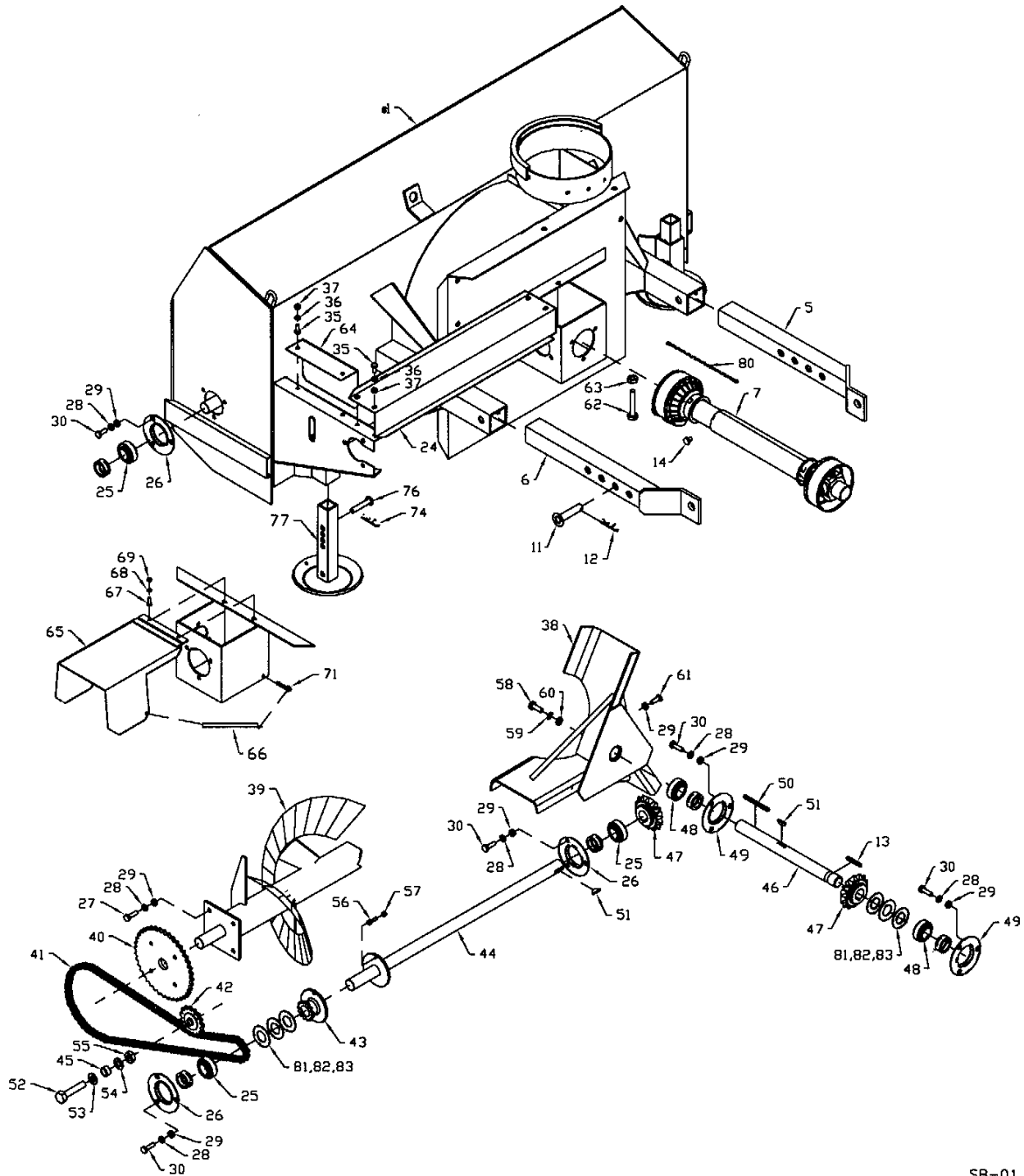

SB-01

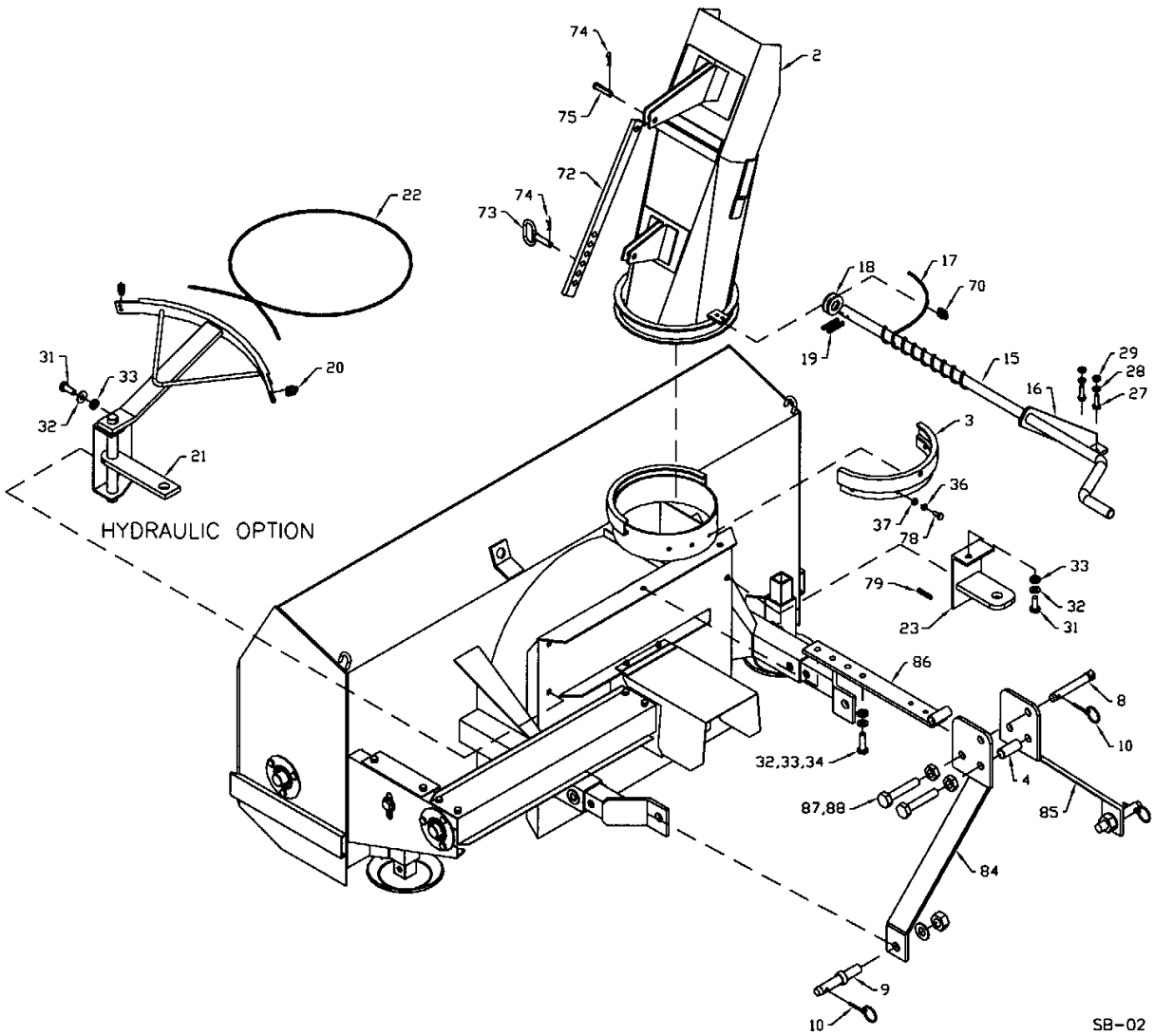

SB-02

WHEN ORDERING PARTS

Always give your dealer the Model, Color and Serial Number of your machine to assist him in ordering and obtaining the correct parts. Use the exploded view and tabular listing of the area of interest to exactly identify the required part.

500 & 600 SNOWBLOWERS

ITEM	PART #	DESCRIPTION
1	905595	Main Body (#500)
	905596	Main Body (#600)
2	965645	Discharge Spout
3	965638	Spout Clamp
4	906770	Hitch Spacer 1"OD x 2 1/4"
5	907127	Hitch Tube Weldt - R
6	907128	Hitch Tube Weldt - L
7	F512	PTO Shaft (#500)
	F612	PTO Shaft (#600)
8	965807	Top Link Pin (Cat. 1)
9	965809	Lift Pin W/ Nut And Washer (Cat.1)
10	965911	7/16" Linch Pin
11	965624	Hitch Pin 3/4" x 3 1/4"
12	12779	#9 Hair Pin Clip (pl)
13	968811	Pto Key - 1/4" x 2"
14	988999	3/8"Dia. x 3/8" Socket Set Screw
15	906667	Crank Handle
16	965634	Crank Mounting Bracket
17	965616	Crank Cable - 3/16" x 84" Long
18	9812438	1" ID x 14 Ga Narrow Rim Washer (pl)
19	9812425	1/4" x 1 1/4" Spring Pin
20	965806	3/16" Cable Clamp
21	965626	Hydraulic Swivel Weldment
22	965627	Hydraulic Cable - 3/16" x 58"
23	965628	Cylinder Mounting Bracket
24	965512	Drive Shaft Guard (#500)
	965644	Drive Shaft Guard (#600)
25	965818	1 1/4" Bearing W/ Collar
26	961637	1 1/4" Bearing Retainer
27	86171	3/8" x 1 1/4" Hex Bolt (pl)
28	81593	3/8" Lock Washer (pl)
29	81592	3/8" Hex Nut (pl)
30	86170	3/8" x 1" Hex Bolt (pl)
31	81620	1/2" x 1 1/4" Hex Bolt (pl)
32	81637	1/2" Lock Washer (pl)
33	81636	1/2" Hex Nut (pl)

34	87553	1/2" x 1 3/4" Hex Bolt (pl)
35	81549	5/16" x 3/4" Hex Bolt (pl)
36	81569	5/16" Lock Washer (pl)
37	81568	5/16" Hex Nut (pl)
38	965630	Fan (#500) (Standard 3-Blade)
	965445	Fan (#500) (4-Blade)
	965642	Fan (#600) (Standard 3-Blade)
	907118	Fan (#600) (4-Blade)
39	965505	Auger (#500)
	965610	Auger (#600)
40	965637	40 Tooth Sprocket - #500 & #600
41	965631	Roller Chain (#50 x 94 Link w/ Conn)
42	965844	Idler Sprocket, 15T, #50
43	965826	Shear Sprocket, 13T, #50
44	965507	Drive Shaft (#500), 1 1/4" x 25 1/2"
	965613	Drive Shaft (#600), 1 1/4" x 30 1/2"
45	965632	Idler Spacer - 1/2" Long
46	965069	Fan Shaft 1 1/4" x 14 1/2"
47	961882	Bevel Gear, 1 1/4" Bore
48	961676	1 1/4" Bearing W/ Collar
49	961675	1 1/4" Bearing Retainer
50	901331	Fan Key - 1/4" x 3 1/2"
51	109343	3/16" x 1 1/8" Woodruff Key
52	84335	5/8" x 2 1/2" Hex Bolt (pl)
53	81678	5/8" Flat Washer BS (pl)
54	81677	5/8" Lock Washer (pl)
55	81676	5/8" Hex Nut (pl)
56	812216	1/4" x 1" Hex Bolt (pl) (Gr. 2)
57	84498	1/4" Lock Nut (pl)
58	81598	7/16" x 1 1/4" Hex Bolt (pl)
59	81615	7/16" Lock Washer (pl)
60	981616	7/16" Flat Washer BS (pl)
61	81213	3/8" x 1" Sq. Hd. Set Screw (pl)
62	81627	1/2" x 3" Hex Bolt (pl)
63	812364	1/2" Lock Nut (pl)
64	965968	Idler Shield
65	965643	Gearbox Lid
66	960135	Pto Guard Spring
67	81525	1/4" x 3/4" Hex Bolt (pl)
68	81545	1/4" Lock Washer (pl)
69	81544	1/4" Hex Nut (pl)
70	961658	1/4" Cable Clamp
71	9812434	1/4" x 1 1/2" Cotter Pin (pl)
72	965646	Spout Adjustment Bar
73	903523	1/2" x 1 1/2" Adjustment Pin Weldment

74	961012	#16 Hair Pin Clip
75	961876	1/2" x 1 1/2" Clevis Pin (pl)
76	901435	1/2" x 2 1/2" Clevis Pin (pl)
77	902477	Skid Plate Weldt
78	812026	5/16" x 1" Hex Bolt (pl)
79	9812426	1/4" x 1 3/4" Spring Pin (pl)
80	936402	PTO Safety Chain
81	9812487	Narrow Rim Washer 1 1/4" x 10ga (pl)
82	967110	Narrow Rim Washer 1 1/4" x 14ga (pl)
83	9812439	Narrow Rim Washer 1 1/4" x 18ga (pl)
84	907133	Hitch Arm Weldt - L
85	907134	Hitch Arm Weldt - R
86	907138	Hitch Top Bar Weldt (#500)
	907139	Hitch Top Bar Weldt (#600)
87	84336	3/4" x 4" Hex Bolt (pl)
88	812365	3/4" Lock Nut (pl)

#500 & #600 SNOWBLOWER PTO SHAFT

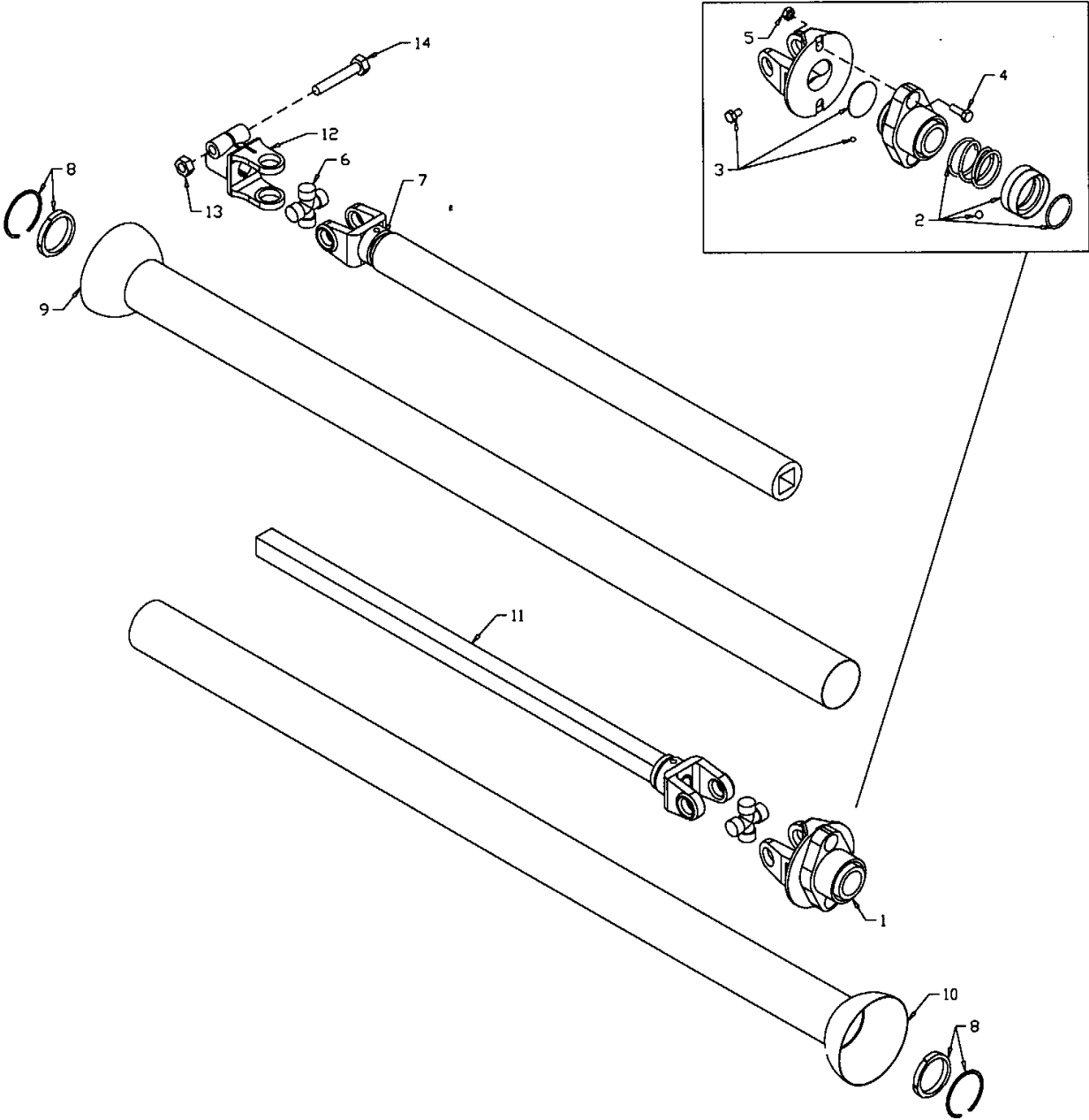

SB-10

500 Farm King Snowblower PTO Parts List

Item #	Part #	Description
	F512	Shaft Complete
	936379	Tractor Half of PTO (shear)
	936380	Implement Half of PTO (clamp yoke)
1	936247	Shear Assembly
2	936168	Spring - Lock Kit (Collar, Spring, Ret. Ring, 2-3/8" Balls)
3	936248	Shear Kit (3/8" x 1/2" Bolt, Blank, 24-1/4" Balls)
4	967270	Shear Bolt 3/8" x 1" (grade 8) - 1 required
5	812363	3/8" Lock Nut
6	936079	Repair Kit (Option)
	906547	Extended Life Repair Kit (Std.)
7	936381	Yoke & Tube
8	936389	Bearing & Snap Ring Kit
9	936382	Inner Guard
10	936383	Outer Guard
11	936384	Yoke & Shaft
12	936254	Clamp Yoke
13	81627	1/2" x 3" Hex Bolt (pl)
14	812364	1/2" Lock Nut (pl)

600 Farm King Snowblower PTO Parts List

Item #	Part #	Description
	F612	Shaft Complete
	936385	Tractor Half of PTO (shear)
	936386	Implement Half of PTO (clamp yoke)
1	936167	Shear Assembly
2	936168	Spring - Lock Kit (Collar, Spring, Ret. Ring, 2-3/8" Balls)
3	936248	Shear Kit
4	903297	Shear Bolt 5/16" x 1" (grade 8) (pack of 10)
5	812362	5/16" Lock Nut
6	936093	Repair Kit (Option)
	906503	Extended Life Repair Kit (Std.)
7	936375	Yoke & Tube
8	936319	Bearing & Snap Ring Kit
9	936391	Inner Guard
10	936377	Outer Guard
11	936378	Yoke & Shaft
12	936262	Clamp Yoke
13	81627	1/2" x 3" Hex Bolt (pl)
14	812364	1/2" Lock Nut (pl)

1.75 X 5 CYLINDER ASSEMBLY

Item #	Part #	Description
	24930	Cyl Complete
1	115367	Tube Weldt
2	112104	Shaft Weldt 1.0 Dia
3	X2669	Seal Kit

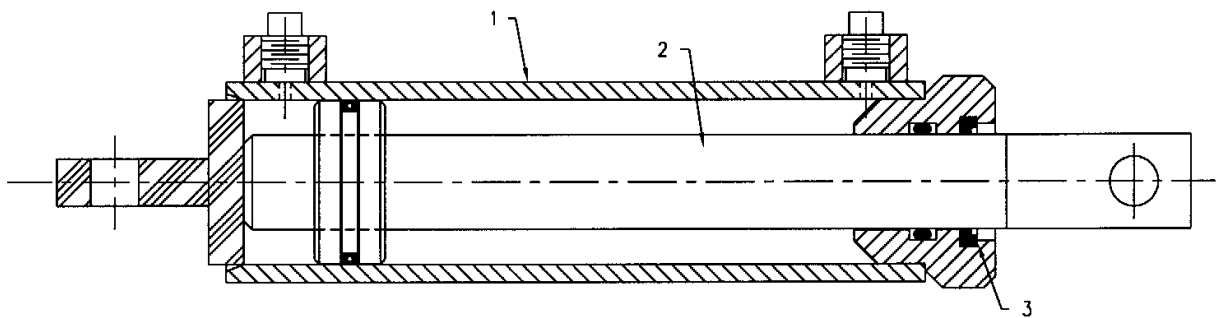

24930

500 & 600 FARM KING SNOWBLOWER BUNDLES

QUANTITY	BUNDLE NO.	DESCRIPTION
-----------------	-------------------	--------------------

#500 Snowblower w/Hand Crank, 3-Blade Fan – Y500

1	F0430	Body Assembly
---	-------	---------------

#600 Snowblower w/Hand Crank, 3-Blade Fan – Y600

1	F0434	Body Assembly
---	-------	---------------

#500 Snowblower w/Hand Crank, 4-Blade Fan – Y500-4

1	F0431	Body Assembly
---	-------	---------------

#600 Snowblower w/Hand Crank, 4-Blade Fan – Y600-4

1	F0435	Body Assembly
---	-------	---------------

OPTIONS AVAILABLE:

F9304	Hydraulic Chute control for #500 & #600 Snowblower (less cylinder)
-------	--

F9305	Hand crank for #500 & #600 Snowblower
-------	---------------------------------------

F512	#500 Snowblower PTO
------	---------------------

F612	#600 Snowblower PTO
------	---------------------

F9117	Deflector Cylinder & Hose Kit for #500 & #600
-------	---

F620	Optional Long PTO for #500 & #600
------	-----------------------------------

DIVISION LOCATIONS

Farm King Division
301 Mountain Street S.
Morden, MB R6M 1X7
Ph.: (204) 822-4467
Fax: (204) 822-6348

Allied Division
1201 Regent Ave. W.
Box 1003
Winnipeg, MB R2C 3B2
Ph.: (204) 661-8711
Fax: (204) 654-2503

Inland Division
675 Washington Ave.
Winnipeg, MB R2K 1M4
Ph: (204) 667-7854
Fax: (204) 669-2599

B.I.I. Division
1330 43rd Street N.W.
Fargo, ND 58102
Ph: (701) 282-7014
Fax: (701) 282-5865

CANADIAN WAREHOUSES

B.C., Abbotsford
(604) 864-2665

AB, Edmonton
(403) 962-6991

SK, Regina
(306) 781-2300

ON, Woodstock
(519) 539-0435

ON, Jasper
(613) 283-1758

QC, Dorion
(450) 455-4840

U.S. WAREHOUSES

AR, West Memphis
(870) 732-3132

GA, Stone Mountain
(770) 908-9439

IA, Lakeview
(712) 657-8585

ID, Meridian
(208) 887-6006

IN, Clarksville
(812) 284-3376

KS, Wichita
(316) 265-9577

MN, Lakeville
(952) 469-5267

MT, Billings
(406) 248-7771

ND, Bismarck
(701) 223-1886

ND, Fargo
(701) 282-7003

NY, Syracuse
(315) 463-5276

OH, Youngstown
(330) 793-0862

OR, Portland
(503) 234-0378

SD, Huron
(605) 352-8616

TX, Houston
(713) 928-2632

UT, Salt Lake City
(801) 972-4321

WI, Portage
(608) 742-1370

OFFSHORE WAREHOUSES

Burando Hill
Katanning
W. Australia
011-618-98-214422

Chihuahua, Mexico
011-52-158-90306

John Kerr Equipment Ltd.
Wilcoxholm Farm
Linlithgow, W. Lothian
Scotland
011-441-506-842280

Skovde, Sweden
011-46-500-452651

Naestved, Denmark
011-45-557-29511

bühler

Buhler Manufacturing *"a partnership"*

301 Mountain Street S.
Morden MB.
R6M 1X7
Ph.: (204) 822-4467
Fax: (204) 822-6348
www.buhler.com