

HONDA

Power

Equipment

Owner's Manual

SNOWBLOWER

HS622

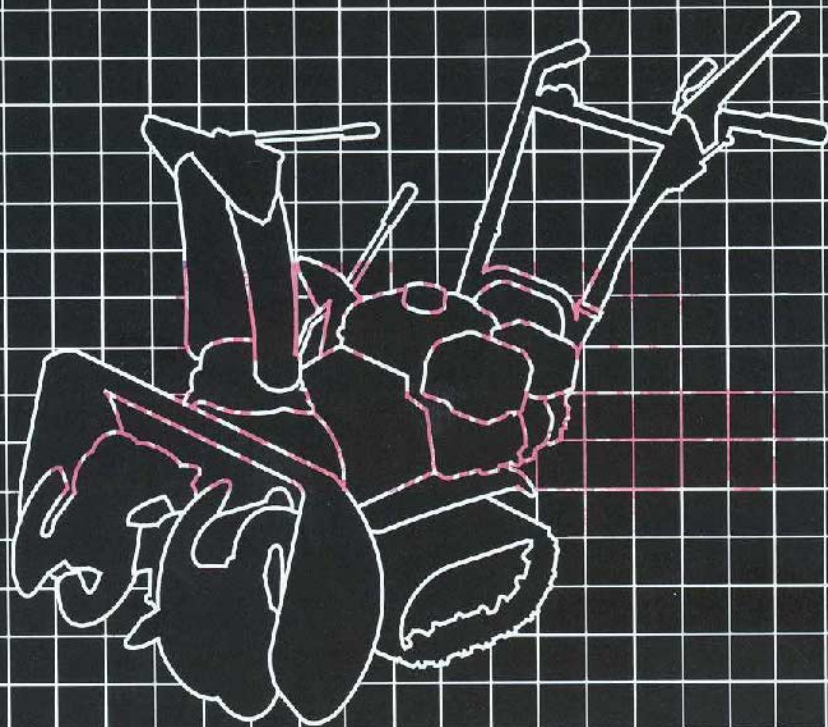



WARNING:



The engine exhaust from this product contains chemicals known to the State of California to cause cancer, birth defects or other reproductive harm.

Thank you for purchasing a Honda snowblower. We want to help you get the best results from your new snowblower and to operate it safely. This manual contains the information on how to do that; please read it carefully.

This owner's manual describes the operation and maintenance of HONDA snowblower: HS622

All information in this publication is based on the latest product information available at the time of printing.

Honda Motor Co., Ltd. reserves the right to make changes at any time without notice and without incurring any obligation.

No part of this publication may be reproduced without written permission.

This manual should be considered a permanent part of the snowblower and should remain with it if it is resold.

Safety Messages

Your safety and the safety of others is very important. We have provided important safety messages in this manual and on the snowblower. Please read these messages carefully.

A safety message alerts you to potential hazards that could hurt you or others. Each safety message is preceded by a safety alert symbol  and one of three words: DANGER, WARNING, or CAUTION.

These mean

 DANGER You **WILL** be **KILLED** or **SERIOUSLY HURT** if you don't follow instructions.

 WARNING You **CAN** be **KILLED** or **SERIOUSLY HURT** if you don't follow instructions.

 CAUTION You **CAN** be **HURT** if you don't follow instructions.

Each message tells you what the hazard is, what can happen, and what you can do to avoid or reduce injury.

Damage Prevention Messages

You will also see other important messages that are preceded by the word NOTICE.

This word means:

NOTICE Your snowblower or other property could be damaged if you don't follow instructions.

The purpose of these messages is to help prevent damage to your snowblower, other property, or the environment.

CONTENTS

SAFETY	3
SAFETY LABEL LOCATIONS	3
SAFETY INFORMATION	4
COMPONENT IDENTIFICATION	7
CONTROLS	8
Engine Switch	8
Fuel Valve	8
Choke Lever	9
Starter Grip	9
Throttle Lever	10
Shift Lever	10
Chute Guide	11
Drive Clutch Lever	11
Auger Clutch Lever	12
Height Adjustment Bolt	12
Skid Plate and Scraper	13
Handle Height Adjusting Bolt	13
PRE-OPERATION CHECK	14
Engine Oil	14
Fuel	15
Auger Bolts	18
Other Checks	18
STARTING THE ENGINE	19
SNOWBLOWER OPERATION	22
Operating the Controls	22
Clearing Snow	26
High Altitude Operation	28
STOPPING THE ENGINE	29
MAINTENANCE	30
The Importance of Maintenance	30
Maintenance Safety	31
Proper Maintenance is the Owner's Responsibility	32
Maintenance Schedule	33
Tools	34
Engine Oil Change	35
Spark Plug Service	36
Track Adjustment	38
Auger and Blower Inspection	39
STORAGE	40
TROUBLESHOOTING	44
SPECIFICATIONS	45
WARRANTY SERVICE INFORMATION	46
INDEX	47

SAFETY LABEL LOCATIONS

These labels warn you of potential hazards that can cause serious injury. Read them carefully.

If a label comes off or becomes hard to read, contact your Honda Snowblower dealer for a replacement.

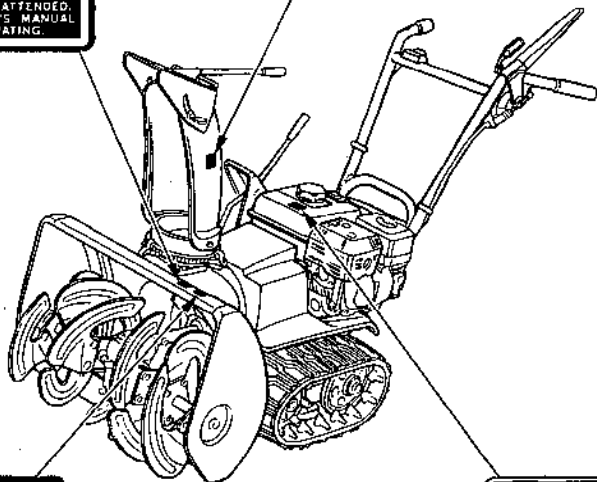
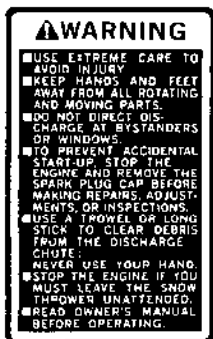

SAFETY INFORMATION

▲WARNING

Most accidents with snowblowers can be prevented if you follow all instructions in this manual and on the snowblower. The most common hazards are discussed below, along with the best way to protect yourself and others.

- Always make a pre-operation check (pages 14 thru 18) before you start the engine. You may prevent an accident or equipment damage.
- Honda snowblowers are designed to give safe and dependable service if operated according to instructions. Read and understand this Owner's Manual before operating the snowblower. Failure to do so could result in personal injury or equipment damage.
- Before operating the snowblower, inspect the area in which you are going to clear snow. Remove debris and other obstacles the snowblower might strike or throw as that may cause injury or damage to the snowblower.
- Inspect the snowblower before operating it. Repair any damage and correct any malfunction before operation.
If you hit an obstacle while operating the snowblower, stop the engine immediately, and check for damage. Damaged equipment may increase the possibility of injury during operation.
- Do not use the snowblower when visibility is poor. Under conditions of poor visibility, there is a greater risk of striking an obstacle or causing injury.
- Never use the snowblower to clear snow from a gravel road or driveway, as rocks may be picked up and ejected. They may cause injury to bystanders.

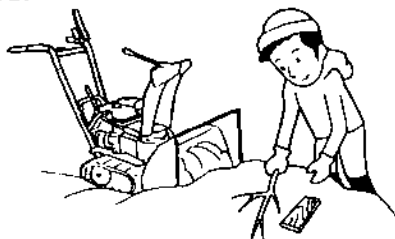

-
- **Adjust the snow discharge chute to avoid hitting the operator, bystanders, windows, and other objects with ejected snow. Stay clear of the snow discharge chute while the engine is running.**
 - **Children and pets must be kept away from the area of operation to avoid injury from flying debris and contact with the snowblower.**
 - **To avoid overturning, be careful when changing the direction of the snowblower while operating it on a slope. Do not use the snowblower to remove snow from roofs. The snowblower may overturn on steep slopes if left unattended, causing injury to the operator or bystanders.**
 - **Know how to stop the snowblower quickly, and understand the operation of all controls.**
 - **Never permit anyone to operate the snowblower without proper instruction. If people or pets suddenly appear in front of the snowblower while it is in operation, immediately release the auger and drive clutch levers to stop the snowblower and avoid possible injury from rotating auger blades.**
 - **If the snow discharge chute becomes clogged, stop the engine and use a wooden stick to unclog it. Never put your hand into the snow discharge chute while the engine is running; serious personal injury could result.**

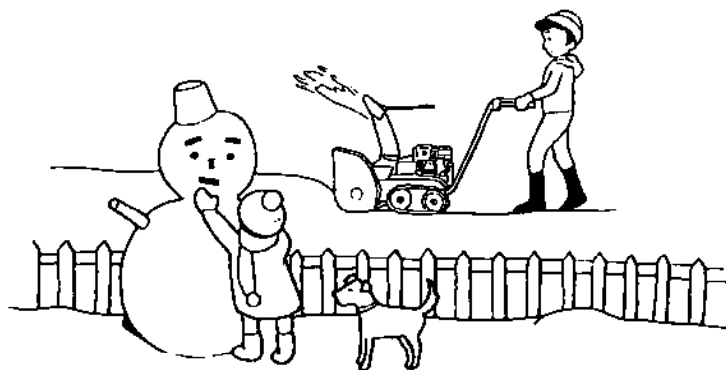

-
- Gasoline is extremely flammable and is explosive under certain conditions.
 - Do not smoke or allow flames or sparks where the snowblower is refueled or where gasoline is stored. Allow the engine to cool down before refueling.
Refuel in a well-ventilated area with the engine stopped.
 - Do not overfill the fuel tank, and make sure the filler cap is closed securely after refueling.
 - Never run the engine in an enclosed or confined area. Exhaust contains poisonous carbon monoxide gas; exposure can cause loss of consciousness and may lead to death.
 - The muffler becomes very hot during operation and remains hot for a while after stopping the engine. Be careful not to touch the muffler while it is hot. Let the engine cool before storing the snowblower indoors.
 - While operating the snowblower, hold the handle firmly, and walk, don't run. Wear suitable winter boots that resist slipping.

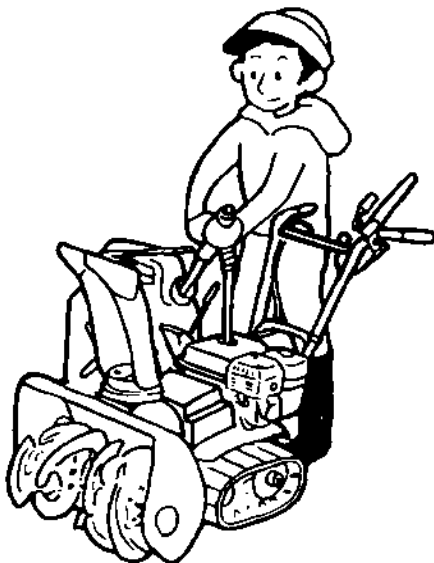

COMPONENT IDENTIFICATION

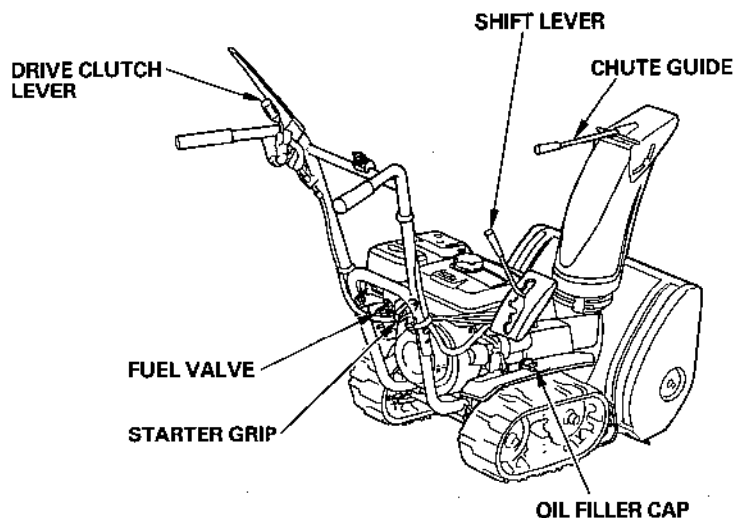
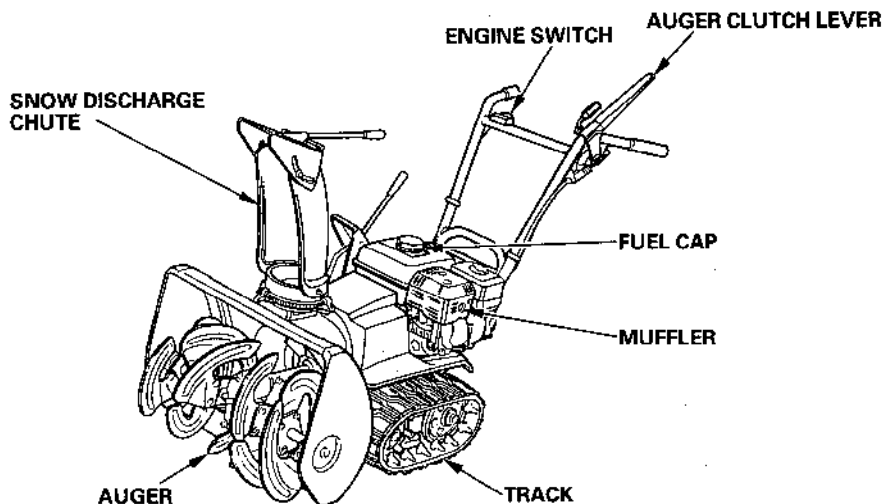

Record the frame and engine serial numbers for your reference. Refer to the serial numbers when ordering parts, and when making technical or warranty inquiries (see page 47).

Frame serial number: _____

Engine serial number: _____

CONTROLS

Engine Switch

Use the engine switch to turn the ignition system ON for starting, and to STOP the engine.

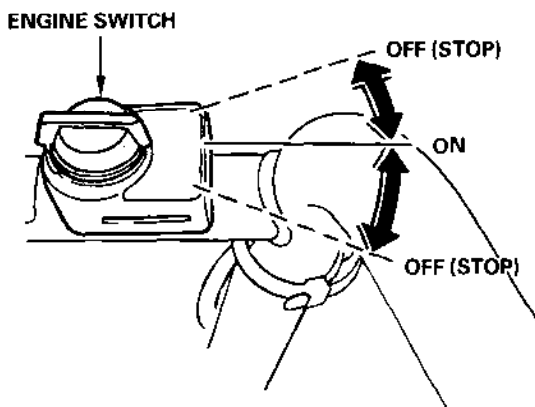

Fuel Valve

The fuel valve opens and closes the fuel line leading from the fuel tank to the carburetor. Make sure that the valve is positioned exactly at either the ON or OFF position. When the snowblower is not in use, always leave the fuel valve in the OFF position to reduce the possibility of fuel leakage.

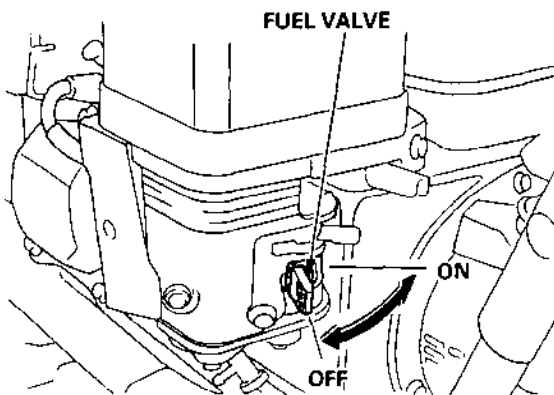

If the snowblower is to be transported from one location to another, be sure to turn the fuel valve to the OFF position. This will prevent carburetor flooding and reduce the possibility of fuel leakage.

Choke Lever

Close the choke when the engine is cold or difficult to start.

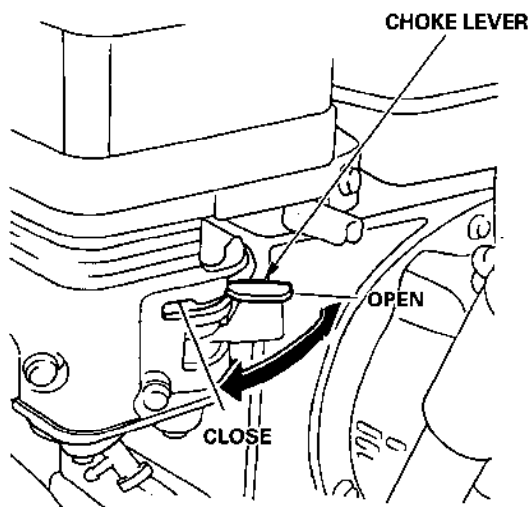

Starter Grip

See page 19 for starting procedures.
Pull this grip to start the engine.

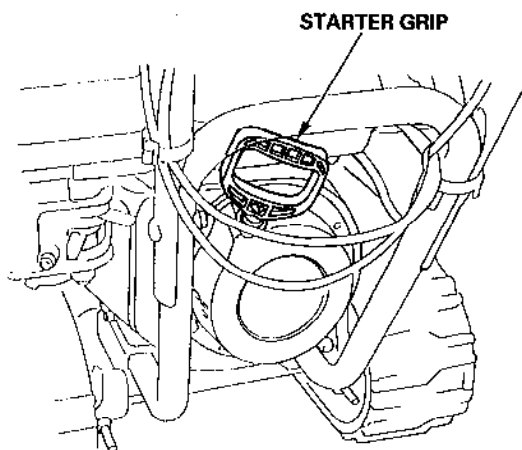

Throttle Lever

Use the throttle lever to select engine speed. In normal operation, use the "FAST" position.

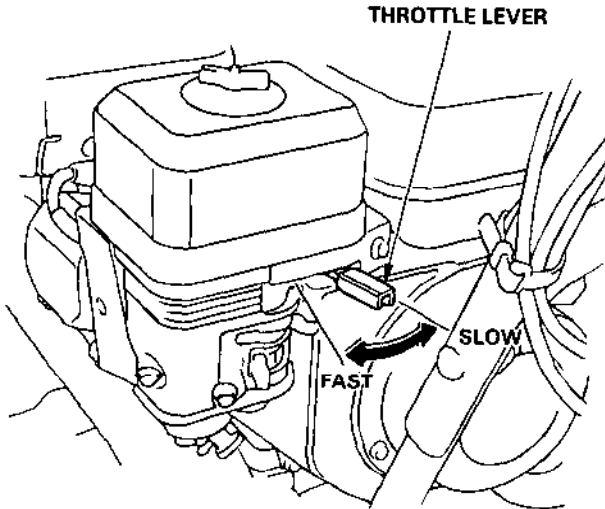

Shift Lever

Use the shift lever to select drive speed or direction.

- (1): LOW SPEED
- (2): HIGH SPEED
- (3): NEUTRAL
- (4): REVERSE

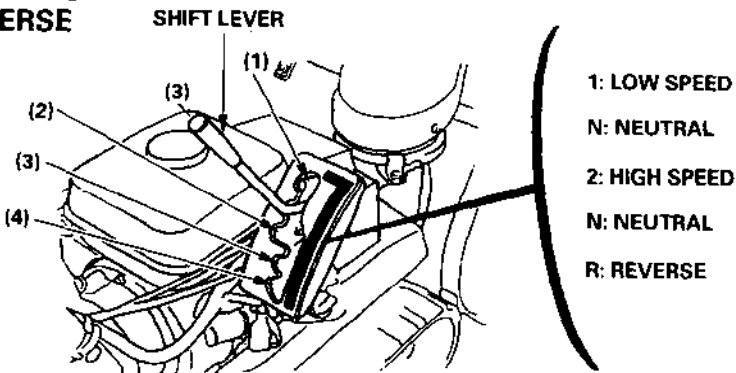

Chute Guide

The chute guide controls the snow discharge angle and direction.

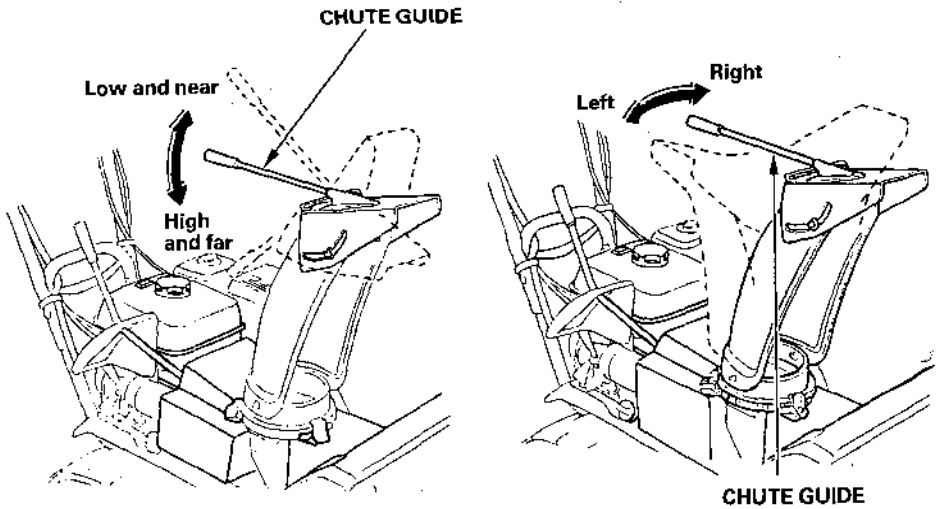

Drive Clutch Lever

Use the drive clutch lever to propel or stop the snowblower.

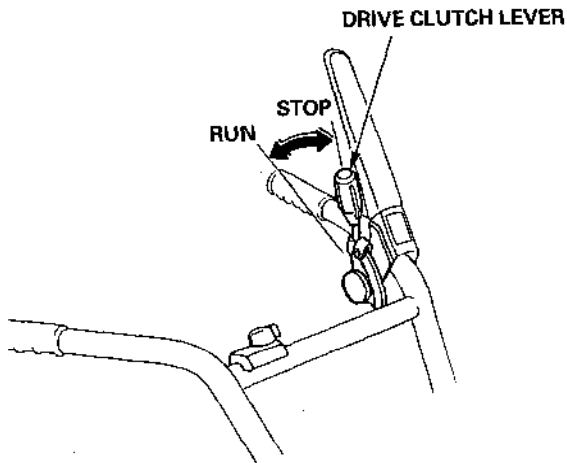

Auger Clutch Lever

Squeezing the auger clutch lever also operates the drive clutch lever; the snowblowing mechanism starts and the snowblower moves forward. Releasing the auger clutch lever stops both the snowblowing mechanism and the forward motion of the snowblower.

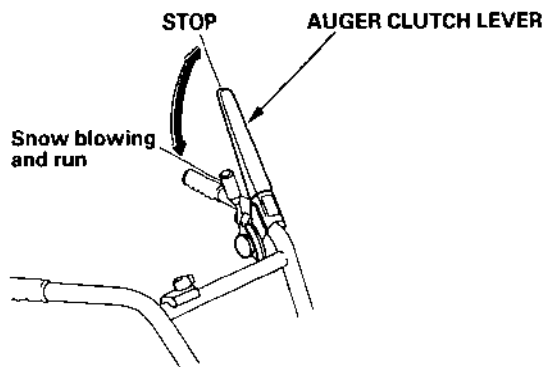

Height Adjustment Bolt

Use the bolt for adjusting the height and angle of the machine in relation to the tracks.

Raise or lower the machine to the desired position. (See page 22)

LOW : Hard snow or fine finish

MIDDLE : Normal use

HIGH : Deep snow or for transporting the snowblower.

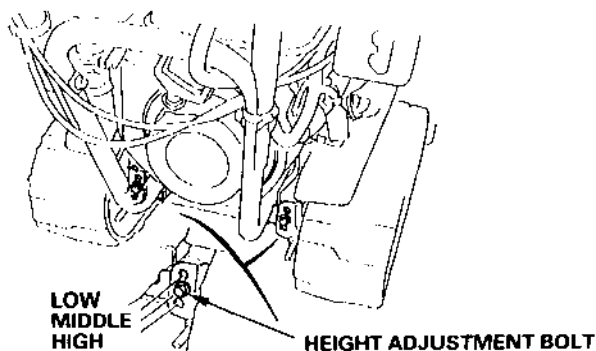

Skid Plate and Scraper

Adjust the skid plates and scraper for the auger housing ground clearance best suited to your snow removal conditions. (See page 22)

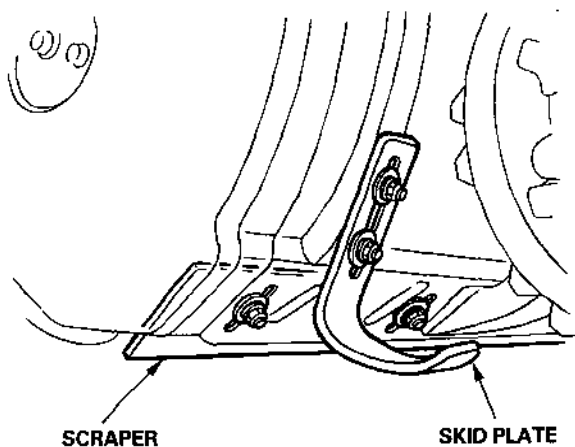

Handle Height Adjusting Bolt

The handlebars can be set in the high, low or middle position to suit the operator. To change handlebar height, remove the right and left adjusting bolts, align the bolt holes for the desired handlebar height, and reinstall the bolts. Tighten the nuts securely.

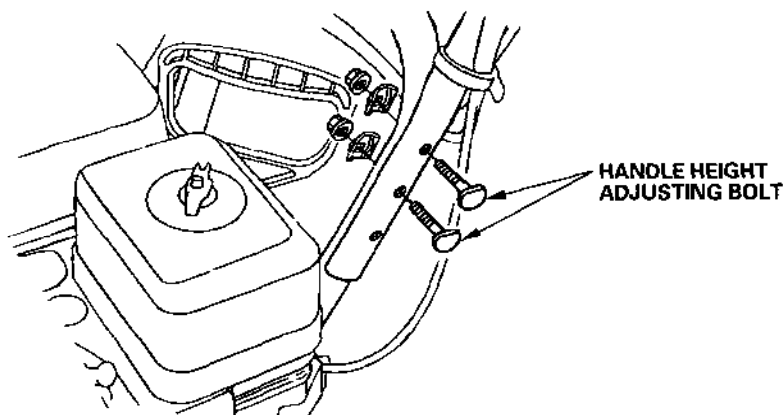

PRE-OPERATION CHECK

Engine Oil

Inspection

With the snowblower on a level surface, remove the oil filler cap and wipe the dipstick clean. Insert the dipstick into the filler neck, but do not screw it in. Remove the dipstick and check the oil level.

If the level is low, fill to the top of the oil filler neck with the recommended oil.

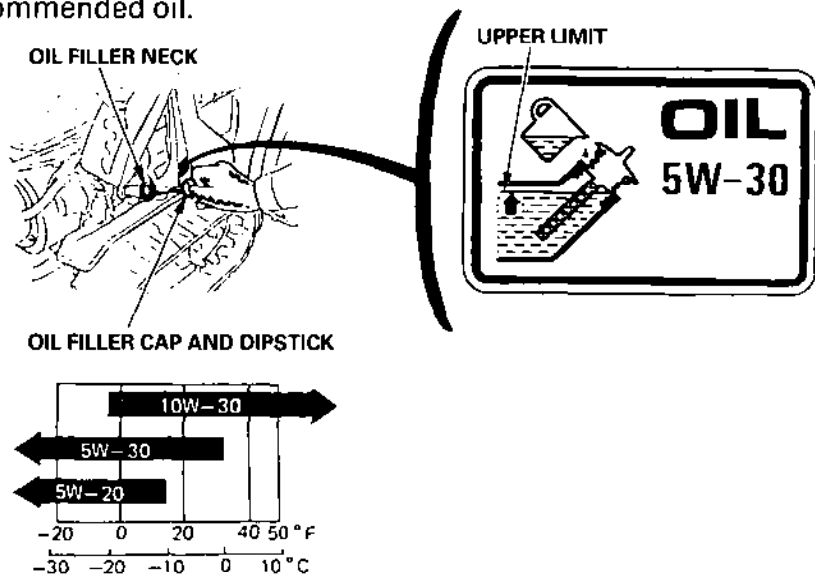

Oil capacity: 0.60 l (0.63 US qt, 0.53 Imp qt)

Recommended oil

Use 4-stroke motor oil that meets or exceeds the requirements for API service classification SF or SG. Always check the API SERVICE label on the oil container to be sure it includes the letters SF or SG.

SAE 5W-30 is recommended for general use. Other viscosities shown in the chart may be used when the average temperature in your area is within the indicated range.

NOTICE

- Using nondetergent oil can shorten the engine's service life, and using 2-stroke oil can damage the engine.
- Running the engine with a low oil level can cause engine damage.

Fuel

Refueling

Fuel tank capacity: 3.5 l (0.92 US gal, 0.77 Imp gal)

Check the fuel level gauge, and refill the tank if the fuel level is low.

▲WARNING

Gasoline is highly flammable and explosive.

You can be burned or seriously injured when handling fuel.

- **Stop the engine and keep heat, sparks, and flames away.**
- **Handle fuel only outdoors.**
- **Wipe up spills immediately.**

Refuel in a well-ventilated area before starting the engine. If the engine has been running, allow it to cool. Refuel carefully to avoid spilling fuel. Do not overfill: there should be no fuel in the filler neck. After refueling, tighten the fuel tank cap securely.

Never refuel the snowblower inside a building where gasoline fumes may reach flames or sparks. Keep gasoline away from appliance pilot lights, barbecues, electric appliances, power tools, etc.

Spilled fuel is not only a fire hazard, it causes environmental damage. Wipe up spills immediately.

NOTICE

Fuel can damage paint and plastic. Be careful not to spill fuel when filling your fuel tank. Damage caused by spilled fuel is not covered under warranty.

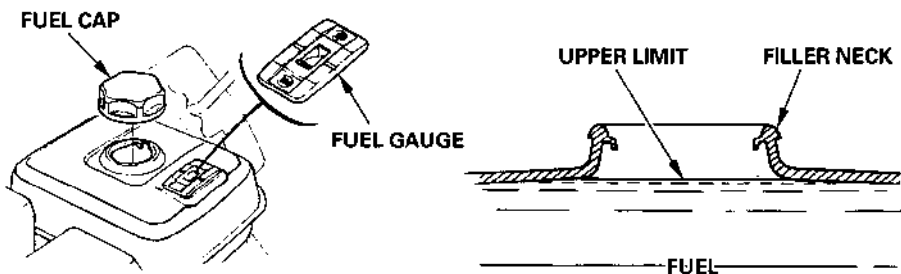

Fuel Recommendations

Use unleaded gasoline with a pump octane rating of 86 or higher.

This engine is designed to operate on unleaded gasoline. Unleaded gasoline produces fewer engine and spark plug deposits and extends exhaust system life.

Never use stale or contaminated gasoline or an oil/gasoline mixture. Avoid getting dirt or water in the fuel tank.

Occasionally you may hear a light "spark knock" or "pinging" (metallic rapping noise) while operating under heavy loads. This is no cause for concern.

If spark knock or pinging occurs at a steady engine speed, under normal load, change brands of gasoline. If spark knock or pinging persists, see an authorized Honda servicing dealer.

NOTICE

Running the engine with persistent spark knock or pinging can cause engine damage.

Running the engine with persistent spark knock or pinging is misuse, and the Distributor's Limited Warranty does not cover parts damaged by misuse.

Oxygenated Fuels

Some conventional gasolines are being blended with alcohol or an ether compound. These gasolines are collectively referred to as oxygenated fuels. To meet clean air standards, some areas of the United States and Canada use oxygenated fuels to help reduce emissions.

If you use an oxygenated fuel, be sure it is unleaded and meets the minimum octane rating requirement.

Before using an oxygenated fuel, try to confirm the fuel's contents. Some states/provinces require this information to be posted on the pump.

The following are the EPA-approved percentages of oxygenates:

ETHANOL — (ethyl or grain alcohol) 10% by volume
You may use gasoline containing up to 10% ethanol by volume. Gasoline containing ethanol may be marketed under the name "Gasohol".

MTBE — (Methyl Tertiary Butyl Ether) 15% by volume
You may use gasoline containing up to 15% MTBE by volume.

METHANOL — (methyl or wood alcohol) 5% by volume
You may use gasoline containing up to 5% methanol by volume, as long as it also contains cosolvents and corrosion inhibitors to protect the fuel system. Gasoline containing more than 5% methanol by volume may cause starting and/or performance problems. It may also damage metal, rubber, and plastic parts of your fuel system.

If you notice any undesirable operating symptoms, try another service station, or switch to another brand of gasoline.

Fuel system damage or performance problems resulting from the use of an oxygenated fuel containing more than the percentages of oxygenates mentioned above are not covered under warranty.

Auger Bolts

Check the auger for loose or broken bolts. If broken, replace them with new ones (page 39).

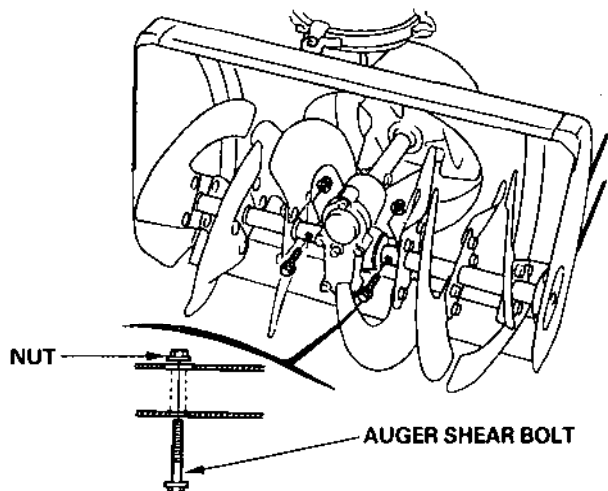

Other Checks

1. Check all bolts, nuts and other fasteners for security.
2. Check each part for operation.
3. Check the entire machine for any other faults which might have been caused in previous operation.

STARTING THE ENGINE

▲WARNING

Never run the engine in an enclosed or confined area. Exhaust contains poisonous carbon monoxide gas; exposure can cause loss of consciousness and may lead to death.

1. Turn the engine switch to the ON position.

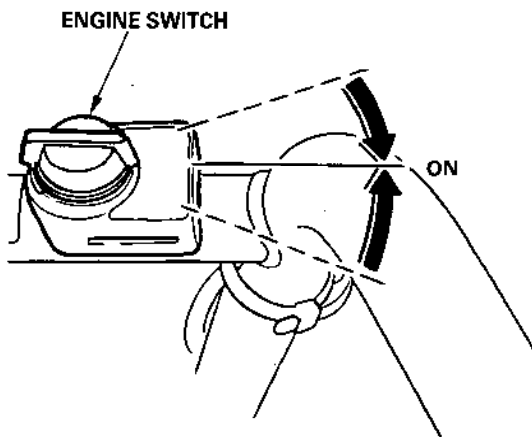

2. Turn the fuel valve to the ON position.
Be sure that the drain knob is tightened securely.

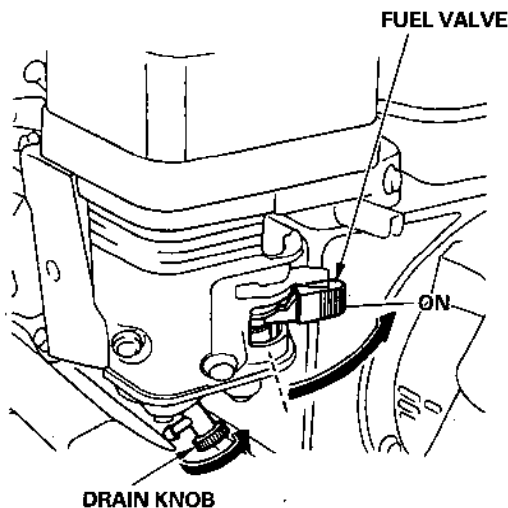

-
3. In cold weather and when the engine is cold, move the choke to the CLOSE position.

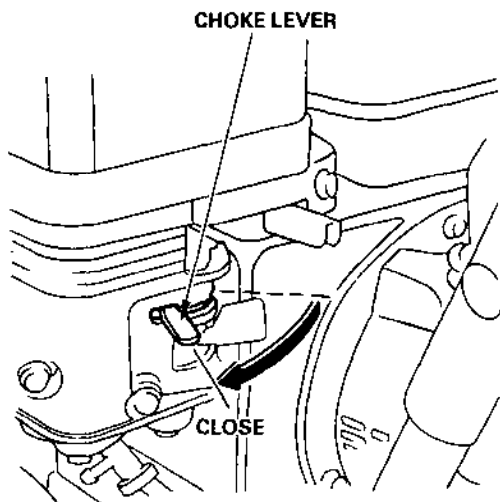

4. Pull the starter grip lightly until you feel resistance, then pull briskly.

NOTICE

- Do not allow the starter grip to snap back against the engine. Return it gently to prevent damage to the starter.
- Damage may result if the starter grip is pulled while the engine is running.

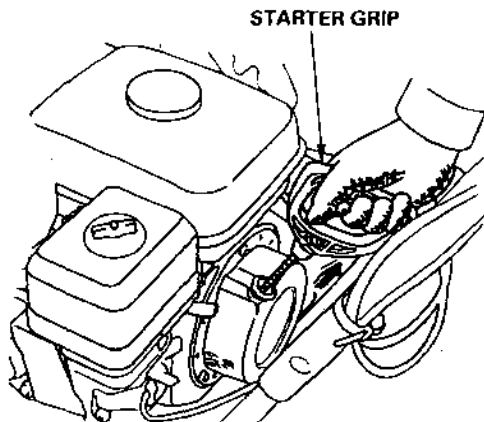

-
5. Let the engine warm up for several minutes. If the choke has been moved to the CLOSE position, gradually move the choke lever to the OPEN position as the engine warms up.

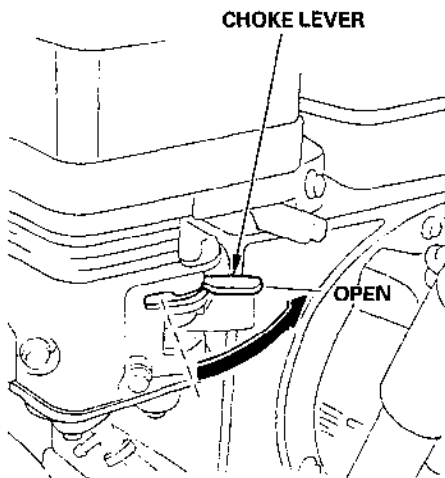

SNOWBLOWER OPERATION

Operating the Controls

1. Adjust the skid plate and scraper positions with the engine stopped and the spark plug cap removed.

The skid plate and scraper have three adjusting positions. Select the position according to the surface conditions described in the chart.

NOTE: Adjust the height equally on both sides.

After adjusting the height, be sure to tighten the adjusting bolts and nuts securely.

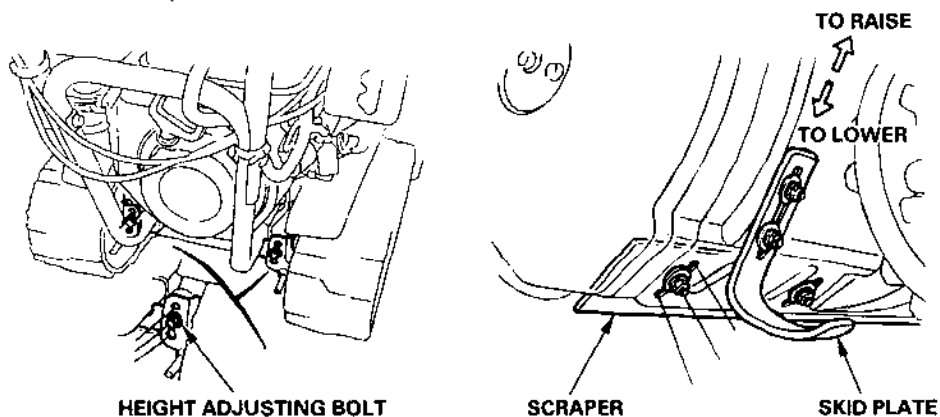

Operation	HEIGHT, ADJUSTING BOLT	Scraper	Skid	
Regular work	MIDDLE	Middle position	Middle position	5mm
Clearing of hard, compact snow	UPPER	Upper position	Upper position	2-7mm
Clearing of snow covering uneven ground	LOWER	Upper position	Lower position	25-30mm

2. Start the engine according to the procedures described on page 19 .

Before operating this equipment you should read and understand the Safety information on page 4 thru 6 .

3. Move the throttle lever to the FAST position for normal operation.

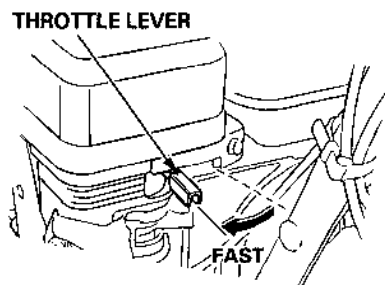

4. Move the shift lever to select the desired drive speed.

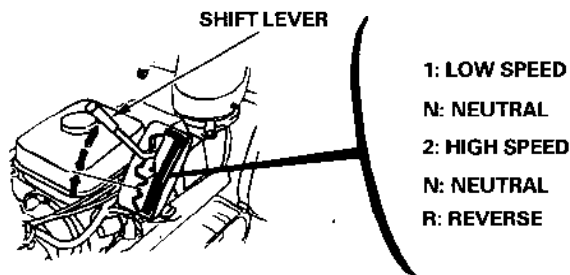

NOTICE

- Be sure to disengage the drive clutch before shifting gears.
- Be sure to set the shift lever into the groove.
- Never move the shift lever while the snowblower is in motion.

NOTE: Low speed (1) is recommended for removing deep or hard-packed snow.

(Drive speed with throttle lever in the fast position)

Shift lever	1	2	R
*Speed	1.12 ft/s (0.34 m/s)	2.79 ft/s (0.85 m/s)	2.79 ft/s (0.85 m/s)

*Speed is stated in meters/second and (feet/second).

-
5. With the shift lever in a forward gear, the machine will move and clear snow simultaneously when you squeeze the auger clutch lever.

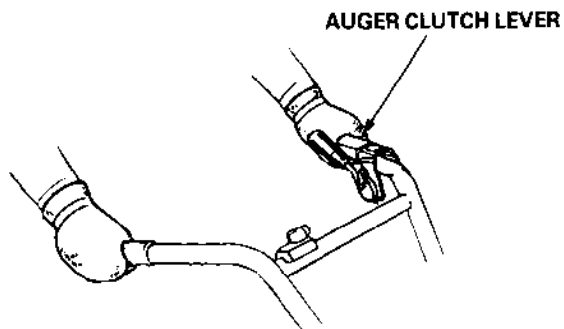

6. To move from one place to another, or to change direction, use the drive clutch lever without squeezing the auger clutch lever.

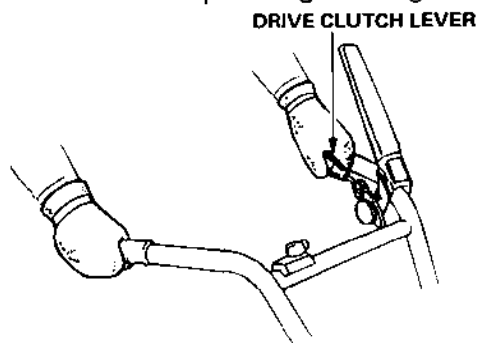

7. To operate the snow-clearing mechanism without moving the machine, set the shift lever in NEUTRAL, then squeeze the auger clutch lever.

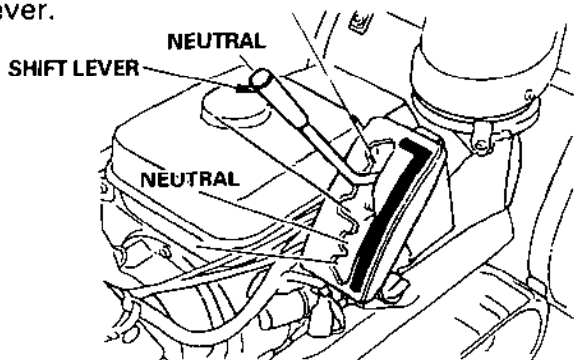

8. Adjust the snow discharge chute guide according to the discharge angle and distance as required.

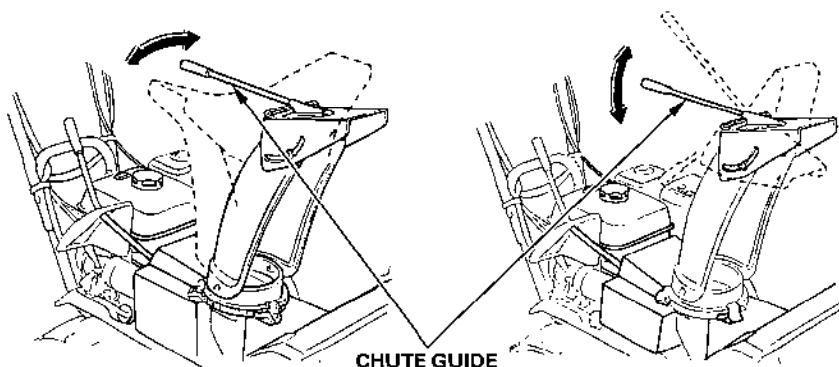

▲ WARNING

- Adjust the snow discharge chute to avoid hitting the operator, bystanders, windows, and other objects with thrown snow. Stay clear of the snow discharge chute while the engine is running.
 - If the snow discharge chute becomes clogged, stop the engine and use a wooden stick to unclog it. Never put your hand into the snow discharge chute while the engine is running; serious personal injury could result.
 - To move from one place to another, or to change direction, use the drive clutch lever. Using the auger clutch lever will cause the snowblowing mechanism to rotate, possibly resulting in equipment damage or personal injury.
9. Release the auger clutch lever to stop clearing snow or moving.

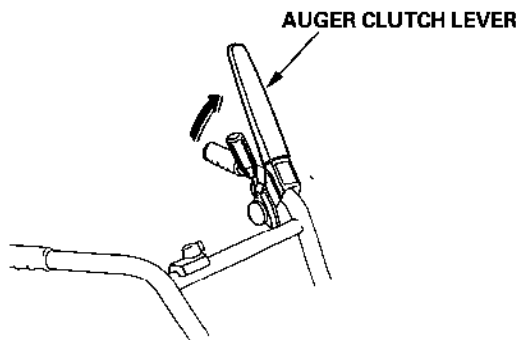

Clearing Snow

For best efficiency, clear snow before it melts, refreezes, and hardens. Do not use the throttle lever to adjust your forward speed. The throttle lever must remain in the FAST position for good snow-clearing performance.

Tips for clearing deep or hard-packed snow

- Clear narrow widths.

Use 1st (low) gear, and clear narrower widths by overlapping your cleared path.

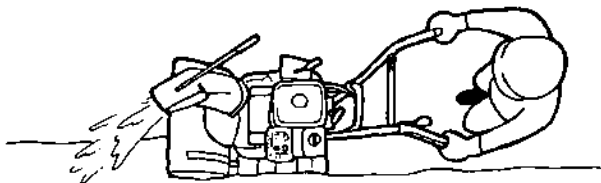

- Clear in steps.

If engine speed decreases in deep, heavy snow, use forward motion intermittently to allow the engine to resume full speed and clear out the auger:

1. Release the auger clutch lever, then move the shift lever to **NEUTRAL**.
2. Squeeze the auger clutch lever, and allow the engine to resume full speed and clear out the auger.
3. Release the auger clutch lever, then move the shift lever to 1st (low) gear.
4. Squeeze the auger clutch lever and resume snow clearing.

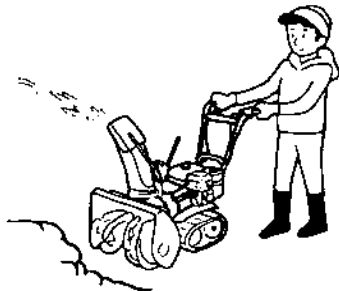

- Clear with back-and-forth motions

If the snow is so hard that the snowblower tends to ride over the surface, move it back and forth to remove snow gradually.

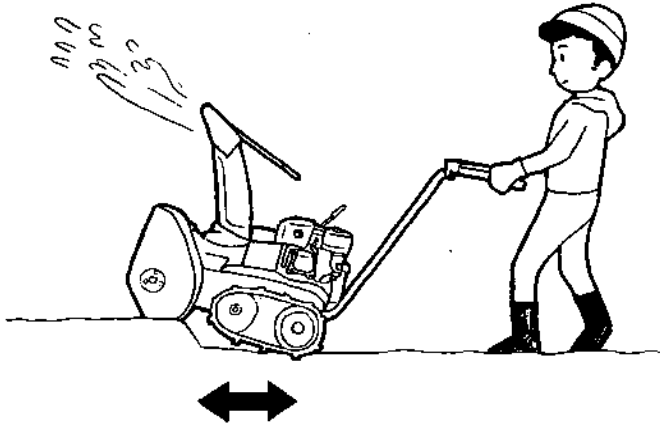

- Clear in layers

If the height of the snow is greater than the height of the snowblowing mechanism, remove it in several layers as shown.

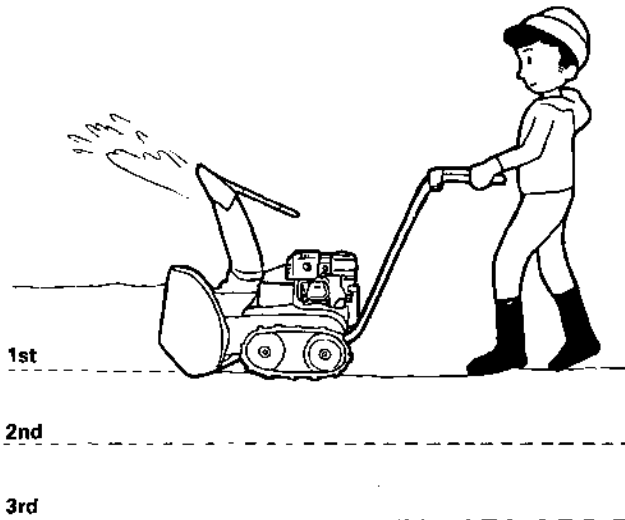

High Altitude Operation

At high altitude, the standard air-fuel mixture will be too rich. Performance will decrease, and fuel consumption will increase. A very rich mixture will also foul the spark plug and cause hard starting.

High altitude performance can be improved by specific modifications to the carburetor. If you always operate your snowblower at altitudes above 6,000 feet (1,800 meters), have your servicing dealer perform this carburetor modification.

Even with carburetor modification, engine horsepower will decrease about 3.5 % for each 1,000 foot (300 meter) increase in altitude. The effect of altitude on horsepower will be greater than this if no carburetor modification is made.

NOTICE

When the carburetor has been modified for high altitude operation, the air-fuel mixture will be too lean for low altitude use. Operation at altitudes below 6,000 feet (1,800 meters) with a modified carburetor may cause the engine to overheat and result in serious engine damage. For use at low altitudes, have your servicing dealer return the carburetor to original factory specifications.

STOPPING THE ENGINE

- In an emergency:

Turn the engine switch to the OFF position.

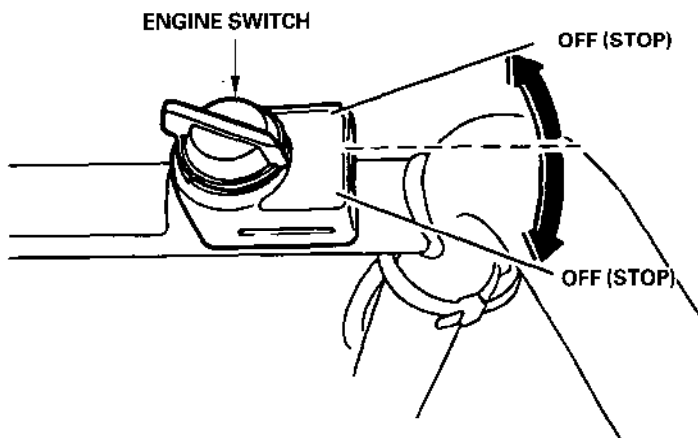

- At normal use:

1. Release the auger clutch lever.
2. Move the drive clutch lever to the NEUTRAL position.
3. Move the throttle lever to the SLOW position.
4. Turn the engine switch to the OFF position.
5. Turn the fuel valve to the OFF position.

MAINTENANCE

The Importance of Maintenance

Good maintenance is essential for safe, economical, and trouble-free operation. It will also help reduce air pollution.

To help you properly care for your snowblower, the following pages include a maintenance schedule, routine inspection procedures, and simple maintenance procedures using basic hand tools. Other service tasks that are more difficult, or require special tools, are best handled by professionals and are normally performed by a Honda technician or other qualified mechanic.

The maintenance schedule applies to normal operating conditions. If you operate your snowblower under unusual conditions, consult your servicing dealer for recommendations applicable to your individual needs and use.

▲WARNING

Improper maintenance, or failure to correct a problem before operation, can cause a malfunction in which you can be seriously hurt or killed.

Always follow the inspection and maintenance recommendations and schedules in this owner's manual.

Maintenance Safety

Some of the most important safety precautions follow. However, we cannot warn you of every conceivable hazard that can arise in performing maintenance. Only you can decide whether or not you should perform a given task.

▲ WARNING

Failure to properly follow maintenance instructions and precautions can cause you to be seriously hurt or killed.

Always follow the procedures and precautions in the owner's manual.

Safety precautions

- Make sure the engine is off before you begin any maintenance or repairs. This will eliminate several potential hazards:
 - **Carbon monoxide poisoning from engine exhaust.**
Be sure there is adequate ventilation whenever you operate the engine.
 - **Burns from hot parts.**
Let the engine and exhaust system cool before touching.
 - **Injury from moving parts.**
Do not run the engine unless instructed to do so.
- Read the instructions before you begin, and make sure you have the tools and skills required.
- To reduce the possibility of fire or explosion, be careful when working around gasoline. Use only a nonflammable solvent, not gasoline, to clean parts. Keep cigarettes, sparks, and flames away from all fuel-related parts.

Remember that your servicing dealer knows your snowblower best and is fully equipped to maintain and repair it.

To ensure the best quality and reliability, use only new, genuine Honda parts or their equivalents for repair or replacement.

Proper Maintenance is the Owner's Responsibility

Replacement parts

The emission control systems on your Honda engine were designed, built, and certified to conform with California emissions regulations. Honda recommends only the use of new, genuine Honda parts or their equivalent. The use of other replacement parts which are not of equivalent quality may impair the effectiveness of your emission control system.

Maintenance

Follow the maintenance schedule on page 33 . Remember that this schedule is based on the assumption that your machine will be used for its designed purpose. Sustained high-load or high-temperature operation, or use in unusually wet conditions, will require more frequent service.

Maintenance schedule

ITEM	SERVICE PERIOD	EACH USE	FIRST 20 HOURS OPERATION	EVERY YEAR	
				BEFORE OPERATION	BEFORE STORAGE
Engine oil	Check level	○			
	Change		○	○(1)	
Spark plug	Clean-Readjust			○(1)	
	Replace	Every 5 years or 300 hours			
	Adjust			○(1)	
Auger and blower, auger housing bolts	Check			○	
Bolts, nuts, fasteners	Check			○	
Sediment cup	Clean				○
Fuel tank and carburetor	Drain				○
Idle speed	Check-adjust	Every 5 years or 300 hours (2)			
Anticorrosion oil	Apply oil				○
Auger clutch cable	Check-Readjust			○(1)(2)	
Auger clutch disk	Check	Every 5 years or 300 hours (2)			
Drive clutch cable	Check-Readjust			○(1)(2)	
Throttle cable	Check-Readjust			○(1)(2)	
Fuel line	Check-(Replace if necessary)	Every 2 years (2)			
Valve clearance	Check-Readjust	Every 5 years or 300 hours (2)			
Fuel tank and strainer	Clean	Every 5 years or 300 hours			

(1) These parts may require more frequent inspection and replacement under heavy use.

(2) These items should be serviced by an authorized Honda dealer, unless the owner has the proper tools and is mechanically proficient. See the Honda Shop Manual for service information.

(3) For professional commercial use, log hours of operation to determine proper maintenance intervals.

Tools

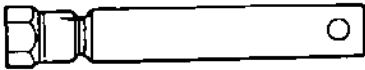

SPARK PLUG WRENCH



WRENCH HANDLE

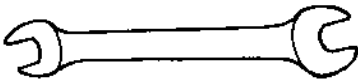

10 x 12 mm WRENCH

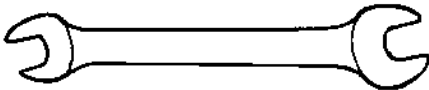

10 x 14 mm WRENCH

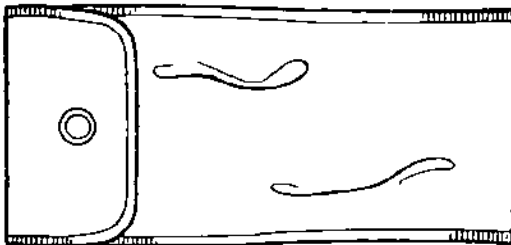

TOOL BAG

SPARE AUGER SHEAR BOLT SET



TWO 6 x 35 mm BOLTS

TWO 6 mm LOCK NUTS

Engine Oil Change

Drain the oil while the engine is still warm to assure rapid and complete draining.

1. Remove the drain plug and filler cap, and drain the oil. Retighten the drain plug securely.
2. Fill the crankcase with the recommended oil (see page 14) and check the level.

Oil capacity: 0.60 l (0.63 US qt , 0.53 Imp qt)

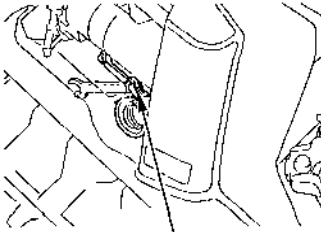

DRAIN PLUG

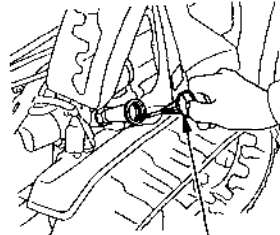

OIL FILLER CAP

UPPER LIMIT



NOTE:

Please dispose of used motor oil in a manner that is compatible with the environment. We suggest you take it in a sealed container to your local recycling center or service station for reclamation. Do not throw it in the trash, pour it on the ground, or down the drain.

Spark Plug Service

Recommended spark plug: BPR5ES (NGK)
W16EPR-U (NIPPONDENSO)

To ensure proper engine operation, the spark plug must be properly gapped and free of deposits. If the engine has been running, the muffler will be very hot. Be careful not to touch the muffler.

1. Remove the spark plug cap.

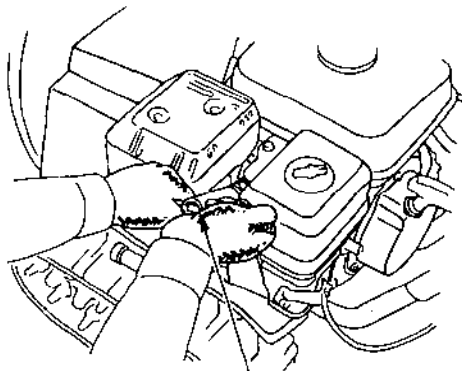

SPARK PLUG WRENCH

2. Clean any dirt from around the spark plug base.
3. Use the wrench supplied in the tool kit to remove the spark plug.
4. Inspect the spark plug. Discard it if the electrodes are worn or if the insulator is cracked or chipped. If it is to be reused, clean the electrode and insulator with a wire brush.

-
5. Measure the plug gap with a feeler gauge.
Correct as necessary by bending the side electrode.
The gap should be:
0.70–0.80 mm (0.028–0.031 in)

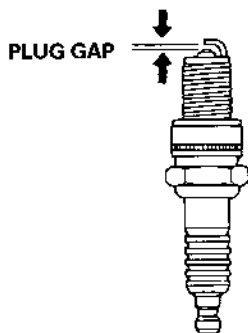

6. Make sure that the spark plug washer is in good condition, and thread the spark plug in by hand to prevent cross-threading.
7. After the spark plug is seated, tighten with a spark plug wrench to compress the washer.

NOTE:

If installing a new spark plug, tighten 1/2 turn after the spark plug seats to compress the washer. If reinstalling a used spark plug, tighten 1/8 to 1/4 turn after the spark plug seats.

NOTICE

- Use only the recommended spark plugs or equivalent. Spark plugs which have an improper heat range may cause engine damage.
- The spark plug must be securely tightened. An improperly tightened spark plug can become very hot and may damage the engine.

Track Adjustment

Make sure the tracks are clean and dry before adjustment. The tracks cannot be correctly adjusted if clogged with snow or debris, or coated with ice.

Check track deflection by pressing down midway between the wheels with a force of 15 kg (33 lb).

When correctly adjusted, it should be:
25.0 – 30.0 mm (0.98 – 1.18 in)

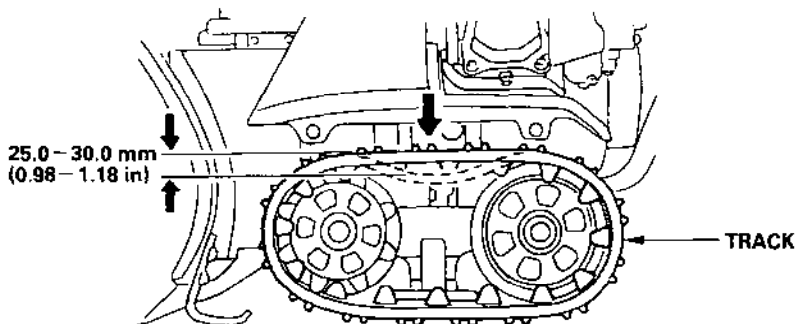

Adjusting procedure

1. Loosen the left and right tension bolt lock nuts at the rear axle, and turn the adjusting nuts to correctly tension both tracks.
2. After adjustment, tighten the lock nuts securely.

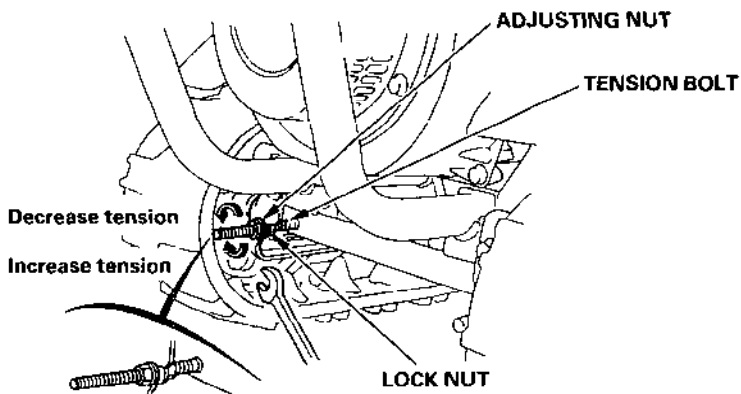

Auger and Blower Inspection

Check the auger, auger housing, blower and shear bolts for signs of damage or other faults. If any of the shear bolts are broken, replace them with the ones furnished with the snowblower. Additional shear bolts and nuts are available from authorized Honda snowblower dealers.

NOTICE

Shear bolts are designed to break under force that would otherwise damage auger and blower parts. Do not replace shear bolts with ordinary hardware bolts.

Shear Bolt Replacement Procedure

1. Place the snowblower on a firm, level surface.
2. Turn the engine switch OFF, and remove the cap from the spark plug.
3. Clean the auger and blower of snow, ice or any other foreign particles.
4. Check the entire snow clearing mechanism.
5. Replace any broken shear bolts. Tighten securely.

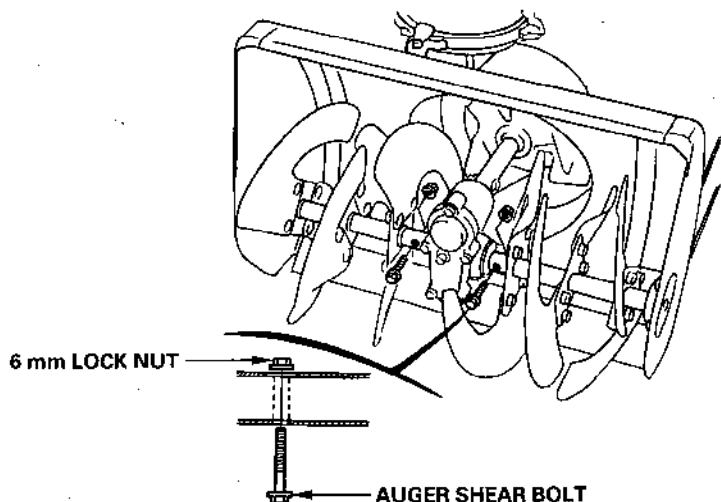

STORAGE

STORAGE TIME	RECOMMENDED SERVICE PROCEDURE TO PREVENT HARD STARTING
Less than 1 month	No preparation required
1 to 2 months	Fill with fresh gasoline and add gasoline conditioner*.
2 months to 1 year	Fill with fresh gasoline and add gasoline conditioner*. Drain the carburetor float bowl and fuel sediment cup (p. 41).
1 year or more	Fill with fresh gasoline and add gasoline conditioner*. Drain the carburetor float bowl and fuel sediment cup (p. 41). Put a tablespoon of oil in the cylinder through the spark plug hole (p. 42). Pull the starter grip several times to distribute the oil in the cylinder. Then pull the starter grip slowly until resistance is felt; this will close the valves so moisture cannot enter the cylinder. After removal from storage, drain the stored gasoline into a suitable container, and fill with fresh gasoline before starting.
<p>*Use gasoline conditioners that are formulated to extend storage life. Contact your authorized Honda snowblower dealer for recommendations for gasoline conditioners.</p>	

Before storing the snowblower for an extended period:

1. Be sure the storage area is free of excessive humidity and dust.
2. Drain the fuel.

▲WARNING

Gasoline is highly flammable and explosive.

You can be burned or seriously injured when handling fuel.

- **Stop the engine and keep heat, sparks, and flames away.**
- **Handle fuel only outdoors.**
- **Wipe up spills immediately.**

- a. Turn the fuel valve ON.
- b. Loosen the carburetor drain knob, and drain the gasoline into a suitable container. After draining, retighten the drain knob and turn the fuel valve OFF.

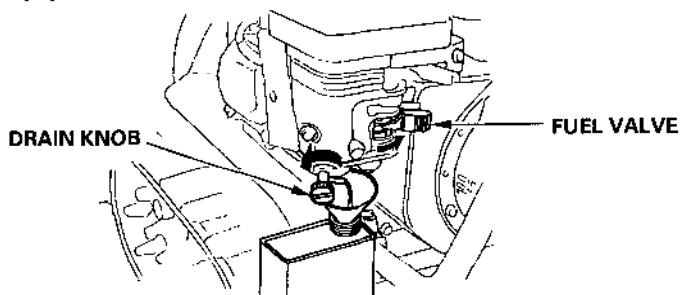

3. Clean the fuel sediment cup.

- a. Turn the fuel valve OFF. Remove, empty, and clean the fuel sediment cup.
- b. Reinstall the cup and packing and tighten securely.

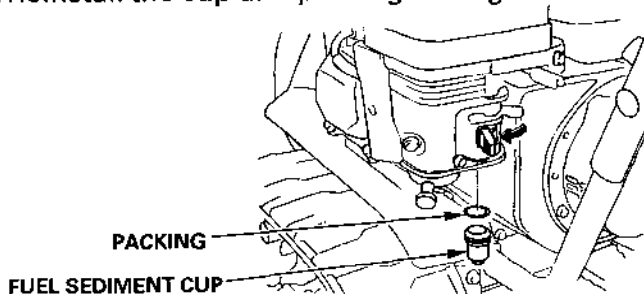

-
4. Remove the spark plug and pour a tablespoon (5–10 cc) of clean motor oil into the cylinder. Pull the starter rope slowly two or three times to distribute the oil. Reinstall the spark plug.

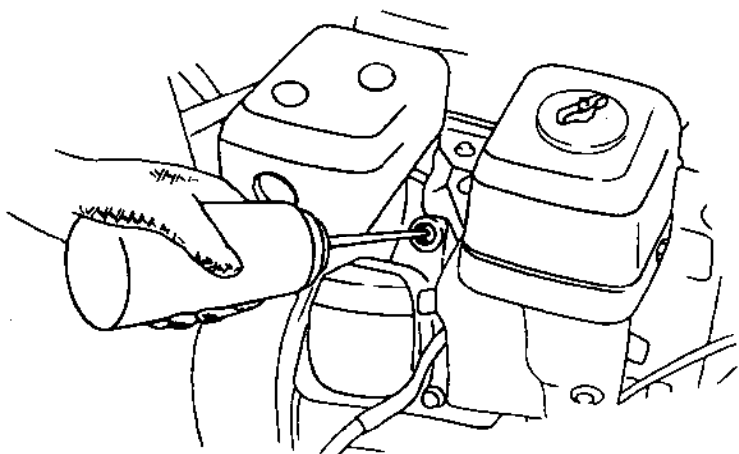

5. Pull the starter grip until resistance is felt. This closes the valves and protects the engine from internal corrosion.

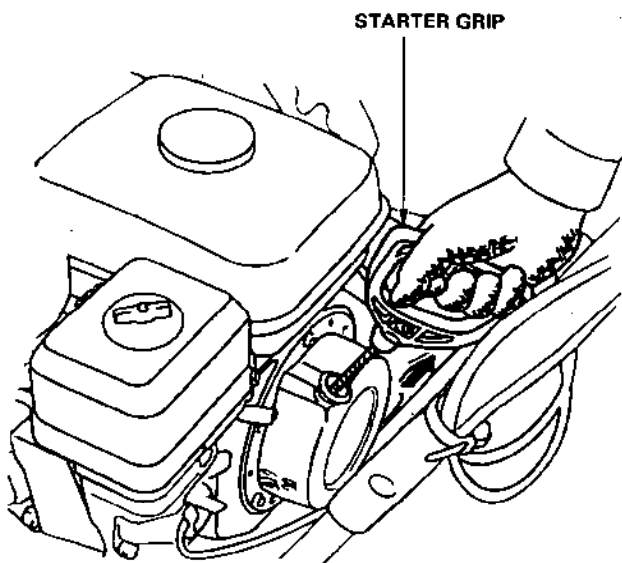

6. Apply oil to the following parts for lubrication and rust prevention.

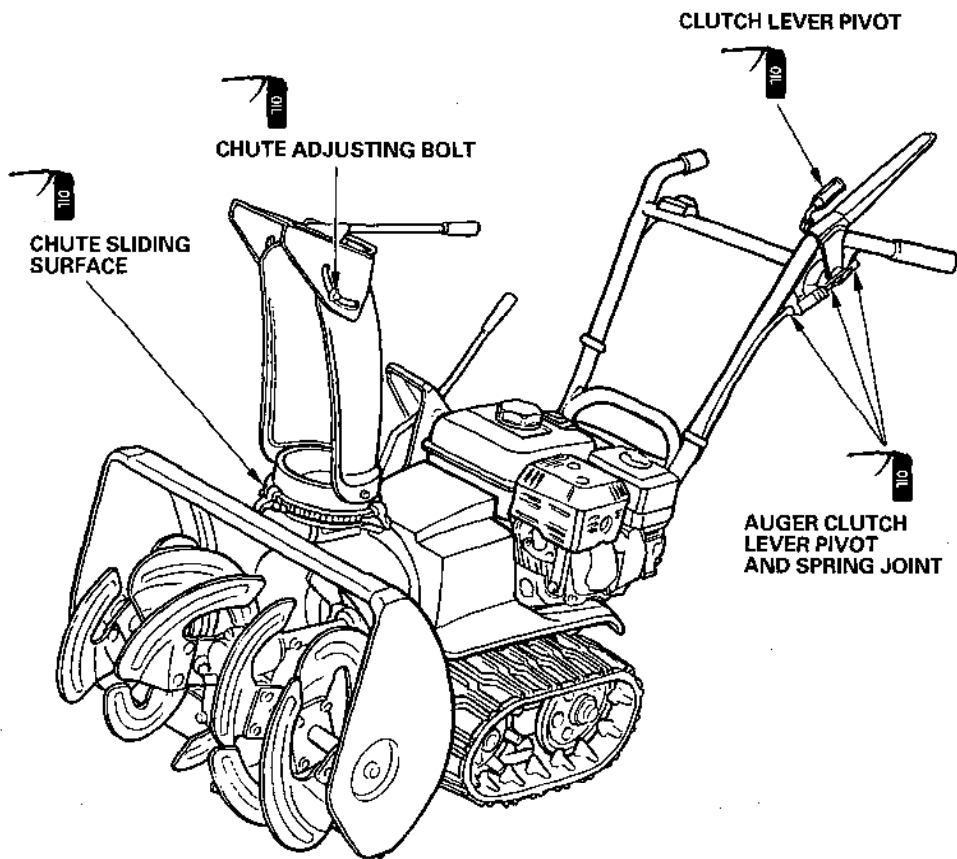

TROUBLESHOOTING

When the engine will not start:

1. Is there enough fuel?
2. Is the fuel valve on?
3. Is gasoline reaching the carburetor?
To check, loosen the drain screw with the fuel valve on. Fuel should flow freely.

▲WARNING

Gasoline is highly flammable and explosive.

You can be burned or seriously injured when handling fuel.

- **Keep heat, sparks, and flames away.**
 - **Handle fuel only outdoors.**
 - **Wipe up spills immediately.**
5. Is the engine switch on?
 6. Is there a spark at the spark plug?
 - a. Remove the spark plug cap. Clean any dirt from around the spark plug base, then remove the spark plug.
 - b. Install the spark plug in the plug cap.
 - c. Turn the engine switch on.
 - d. Ground the side electrode at any engine ground and crank the engine to see if sparks jump across the gap.

▲WARNING

Gasoline is highly flammable and explosive.

If ignited, gasoline can burn you severely.

- **Be sure there is no spilled fuel near the engine.**
 - **Place the spark plug away from the spark plug hole.**
- e. If there are no sparks, replace the plug. If sparks occur, try to start the engine according to the instructions.
7. If the engine still does not start, take the snowblower to an authorized Honda dealer.

If the auger or blower does not operate, check the shear bolts (p. 39). Replacement shear bolts and nuts were supplied with your snowblower. Additional shear bolts and nuts are available from authorized Honda snowblower dealers. Do not replace shear bolts with ordinary hardware bolts.

SPECIFICATIONS

Frame

Model	HS622
Type	TA
Items	
Power equipment discription code	SZAL
Overall length	1,460 mm (57.5 in)
Overall width	550 mm (21.7 in)
Overall height	1,125 mm (44.3 in)
Dry weight	66 kg (146 lbs)
Width of snow clearance	550 mm (21.7 in)
Height of snow clearance	420 mm (16.5 in)
Snow throwing distance (differs according to the kind of snow)	Max. 14 m (45.9 ft)
Clearing capacity	35 Ton/hour
Continuous operating time	3 hours

Engine

Model	HONDA GX160 K1
Maximum output	4.9 hp at 4,000 rpm
Displacement	163 cm ³ (9.9 cu-in)
Bore × stroke	68 × 45 mm (2.7 × 1.8 in)
Starting method	Recoil starter, Recoil or electric starter
Ignition system	Transistorized magneto
Oil capacity	0.60 ℓ (0.63 US qt , 0.53 Imp qt)
Fuel tank capacity	3.5 ℓ (0.92 US gal , 0.77 Imp gal)
Spark plug	BPR5ES (NGK) , W16EPR-U (NIPPONDENSO)

Tuneup

ITEM	SPECIFICATION	MAINTENANCE
Spark plug gap	0.70–0.80 mm (0.028–0.031 in)	Refer to page: 37
Valve clearance	IN: 0.15 ± 0.02 mm EX: 0.20 ± 0.02 mm	See your authorized Honda dealer
Other specifications	No other adjustments needed.	

NOTE: Specifications are subject to change without notice.

WARRANTY SERVICE INFORMATION

Honda power equipment dealership personnel are trained professionals. They should be able to answer any question you may have. If you encounter a problem that your dealer does not solve to your satisfaction, please discuss it with the dealership's management. The Service Manager or General Manager can help. Almost all problems are solved in this way.

If you are dissatisfied with the decision made by the dealership's management, contact the Honda Power Equipment Customer Service Office. You can write to:

American Honda Motor Co., Inc.
Honda Power Equipment Division
Customer Service Office
4475 River Green Parkway
Duluth, Georgia 30136-2565

Or telephone: (770)497-6400

When you write or call, please give us this information:

- Model and serial number
- Name of dealer who sold the snowblower to you
- Name and address of dealer who services your snowblower
- Date of purchase
- Your name, address, and telephone number
- A detailed description of the problem

COMPONENT IDENTIFICATION.....	7
CONTENTS	2
CONTROLS	8
Auger Clutch Lever	12
Choke Lever.....	9
Chute Guide	11
Drive Clutch Lever	11
Engine Switch	8
Fuel Valve.....	8
Handle Height Adjusting Bolt	13
Height Adjustment Bolt.....	12
Shift Lever	10
Skid Plate and Scraper	13
Starter Grip.....	9
Throttle Lever.....	10
MAINTENANCE	30
Auger and Blower Inspection	39
Engine Oil Change	35
Maintenance Schedule.....	33
Proper Maintenance is the Owner's Responsibility	32
Maintenance Safety.....	31
Spark Plug Service.....	36
The Importance of Maintenance	30
Tools	34
Track Adjustment.....	38
PRE-OPERATION CHECK	14
Auger Bolts.....	18
Engine Oil	14
Fuel	15
Other Checks	18
SAFETY	3
SAFETY LABEL LOCATIONS	3
SAFETY INFORMATION	4
SNOWBLOWER OPERATION	22
Clearing Snow.....	26
Operating the Controls.....	22
High Altitude Operation	28
SPECIFICATIONS.....	45
STARTING THE ENGINE	19
STOPPING THE ENGINE	29
STORAGE.....	40
TROUBLESHOOTING.....	44
WARRANTY SERVICE INFORMATION	46

HONDA
HONDA MOTOR CO., LTD. TOKYO, JAPAN

31743700
00X31-743-7000

AP 英 Y 20009607
PRINTED IN JAPAN