

Husqvarna



9027ST

Owner's Manual



SAFETY RULES



Safe Operation Practices for Snow Throwers

IMPORTANT: This machine is capable of amputating hands and feet and throwing objects. Failure to observe the following safety instructions could result in serious injury or death.



Look for this symbol to point out important safety precautions. It means CAUTION!!! BECOME ALERT!!! YOUR SAFETY IS INVOLVED.



WARNING: Always disconnect spark plug wire and place it where it cannot contact plug in order to prevent accidental starting when setting up, transporting, adjusting or making repairs.



WARNING: This snow thrower is for use on sidewalks, driveways and other ground level surfaces. Caution should be exercised while using on sloping surfaces. Do not use snow thrower on surfaces above ground level such as roofs of residences, garages, porches or other such structures or buildings.



WARNING: Snow throwers have exposed rotating parts, which can cause severe injury from contact, or from material thrown from the discharge chute. Keep the area of operation clear of all persons, small children and pets at all times including startup.



CAUTION: Muffler and other engine parts become extremely hot during operation and remain hot after engine has stopped. To avoid severe burns on contact, stay away from these areas.



WARNING: Engine exhaust, some of its constituents, and certain vehicle components contain or emit chemicals known to the State of California to cause cancer and birth defects or other reproductive harm.

TRAINING

- Read the operating and service instruction manual carefully. Be thoroughly familiar with the controls and the proper use of the equipment. Know how to stop the unit and disengage the controls quickly.
- Never allow children to operate the equipment. Never allow adults to operate the equipment without proper instruction.
- Keep the area of operation clear of all persons, particularly small children and pets.
- Exercise caution to avoid slipping or falling especially when operating in reverse.

PREPARATION

- Remove foreign objects. Thoroughly inspect the area where the equipment is to be used and remove all doormats, sleds, boards, wires, rocks & landscaping.
- Disengage all clutches before starting engine (motor).

- Do not operate the equipment without wearing adequate winter outer garments. Avoid loose, dangling clothing, such as scarves, which can get caught in rotating parts. Wear footwear that will improve footing on slippery surfaces.
- Handle fuel with care; it is highly flammable.
 - Never smoke while refueling.
 - Use an approved fuel container.
 - Never remove fuel tank cap or add fuel to a running engine (motor) or hot engine (motor).
 - Fill fuel tank outdoors with extreme care. Never fill fuel tank indoors.
 - Replace fuel cap securely and wipe up spilled fuel.
 - Never store fuel or snow thrower with fuel in the tank inside of a building where fumes may reach an open flame or spark.
 - Check fuel supply before each use, allowing space for expansion as the heat of the engine (motor) and/or sun cause fuel to expand.

STATIC ELECTRICITY HAZARD -

- Never fill containers inside a vehicle or on a truck or trailer bed with a plastic liner. Always place containers on the ground, away from your vehicle before filling.
- When practical, remove gas-powered equipment from the truck or trailer and refuel it on the ground. If this is not possible, then refuel such equipment on a trailer with a portable container, rather than from a gasoline dispenser nozzle.
- Keep the nozzle in contact with the rim of the fuel tank opening at all times, until refueling is complete. Do not use a nozzle lock-open device.
- If fuel is spilled on clothing, change clothing immediately.

- For all units with electric starting motors use electric starting extension cords certified CSA/UL. Use only with a receptacle that has been installed in accordance with local inspection authorities.
- If snow thrower must be operated over gravel surface, use extra caution and be sure skid plates are adjusted to lowest (highest scraper clearance) position.
- Never attempt to make any adjustments while the engine (motor) is running (except when specifically recommended by manufacturer).
- Let engine (motor) and snow thrower adjust to outdoor temperatures before starting to clear snow.
- Always wear safety glasses or eye shields during operation or while performing an adjustment or repair to protect eyes from foreign objects that may be thrown from the snow thrower.

OPERATION

- Do not operate this machine if you are under the influence of alcohol or taking drugs or other medication which can cause drowsiness or affect your ability to operate this machine.
- Do not use this machine if you are mentally or physically unable to operate this machine safely.

- Do not put hands or feet near or under rotating parts. Keep clear of the discharge opening and front auger area at all times.
- Exercise extreme caution when operating on or crossing gravel drives, walks or roads. Stay alert for hidden hazards or traffic.
- After striking a foreign object, stop the engine (motor), remove wire from the spark plug, thoroughly inspect snow thrower for any damage, and repair the damage before restarting and operating the snow thrower.
- If the unit should start to vibrate abnormally, stop the engine (motor) and check immediately for the cause. Vibration is generally a warning of trouble.
- Stop the engine (motor) whenever you leave the operating position, before unclogging the auger/impeller housing or discharge chute and when making any repairs, adjustments, or inspections.
- When cleaning, repairing, or inspecting, make certain all controls are disengaged and the auger/impeller and all moving parts have stopped. Disconnect the spark plug wire and keep the wire away from the spark plug to prevent accidental starting.
- Take all possible precautions when leaving the snow thrower unattended. Disengage the auger/impeller, stop engine (motor), and remove key.
- Do not run the engine (motor) indoors, except when starting the engine (motor) and for transporting the snow thrower in or out of the building. Open the outside doors.



WARNING: Exhaust fumes are dangerous (containing CARBON MONOXIDE, an ODORLESS and DEADLY GAS).

- Do not clear snow across the face of slopes. Exercise extreme caution when changing direction on slopes. Do not attempt to clear steep slopes.
- Never operate the snow thrower without proper guards, plates or other safety protective devices in place.
- Never operate the snow thrower near glass enclosures, automobiles, window wells, drop-offs, and the like without proper adjustment of the snow discharge angle. Keep children and pets away.

CONGRATULATIONS on your purchase of a new snow thrower. It has been designed, engineered and manufactured to give best possible dependability and performance.

Should you experience any problem you cannot easily remedy, please contact your nearest authorized service center/department. We have competent, well-trained technicians and the proper tools to service or repair this unit.

Please read and retain this manual. The instructions will enable you to assemble and maintain your snow thrower properly. Always observe the "SAFETY RULES".

SERIAL NUMBER: _____

DATE OF PURCHASE: _____

THE MODEL AND SERIAL NUMBERS WILL BE FOUND ON A DECAL ATTACHED TO THE REAR OF THE SNOW THROWER HOUSING.

YOU SHOULD RECORD BOTH SERIAL NUMBER AND DATE OF PURCHASE AND KEEP IN A SAFE PLACE FOR FUTURE REFERENCE.

- Do not overload the machine capacity by attempting to clear snow at too fast a rate.
- Never operate the machine at high transport speeds on slippery surfaces. Look behind and use care when backing up.
- Never direct discharge at bystanders or allow anyone in front of the unit.
- Disengage power to the auger/impeller when snow thrower is transported or not in use.
- Use only attachments and accessories approved by the manufacturer of the snow thrower (such as wheel weights, counterweights, cabs, tire chains, electric start kits, etc.).
- Never operate the snow thrower without good visibility or light. Always be sure of your footing and keep a firm hold on the handles. Walk; never run.
- Do not overreach. Keep proper footing and balance at all times.
- This snow thrower is for use on sidewalks, driveways and other ground level surfaces.
- Do not use the snow thrower on surfaces above ground level such as roofs of residences, garages, porches or other such structures or buildings.

MAINTENANCE AND STORAGE

- Check shear bolts and other bolts at frequent intervals for proper tightness to be sure the equipment is in safe working condition.
- Never store the snow thrower with fuel in the tank inside a building where ignition sources are present such as hot water and space heaters, clothes dryers, and the like. Allow the engine (motor) to cool before storing in any enclosure.
- Always refer to operator's guide instructions for important details if the snow thrower is to be stored for an extended period.
- Maintain or replace safety and instruction labels, as necessary.
- Run the snow thrower, with auger engaged, a few minutes after throwing snow to clear the machine and prevent freeze-up of the auger/impeller.

PRODUCT SPECIFICATIONS

Gasoline Capacity and Type:	4.0 Quarts Unleaded Regular only
Oil Type (API-SF-SJ):	SAE 30 (above 40°F) SAE 5W-30 or 10W-30 (0° to +40°F) SAE 0W-30 (below 0°F)
Oil Capacity:	26 Ounces
Spark Plug:	Champion RN4C (Gap: .030")

CUSTOMER RESPONSIBILITIES

- Read and observe the safety rules.
- Follow a regular schedule in maintaining, caring for and using your snow thrower.
- Follow the instructions under "Maintenance" and "Storage" sections of this owner's manual.

SAFETY RULES 2-3
 PRODUCT SPECIFICATIONS 3
 CUSTOMER RESPONSIBILITIES 3
 WARRANTY 32
 ASSEMBLY 5-7
 OPERATION 8-13

MAINTENANCE 14-15
 MAINTENANCE SCHEDULE 14
 SERVICE AND ADJUSTMENTS 16-18
 STORAGE 18
 TROUBLESHOOTING 19
 REPAIR PARTS 20-31

PARTS PACKED SEPARATELY IN CARTON

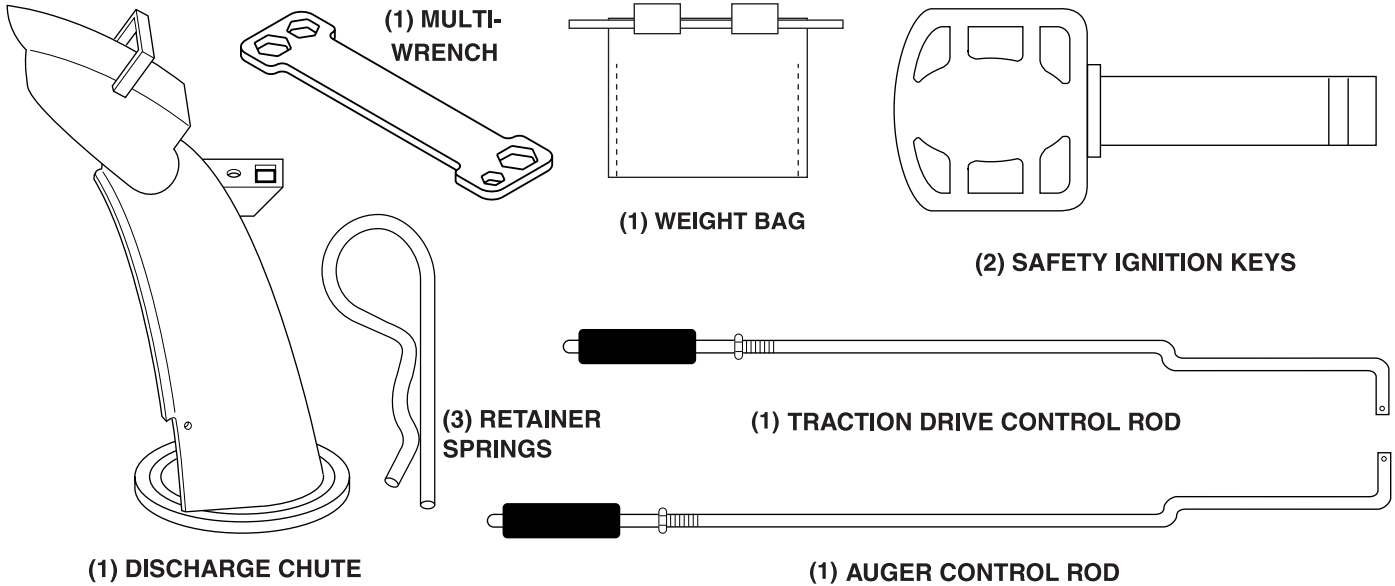

EXTRA SHEAR BOLTS AND NUTS

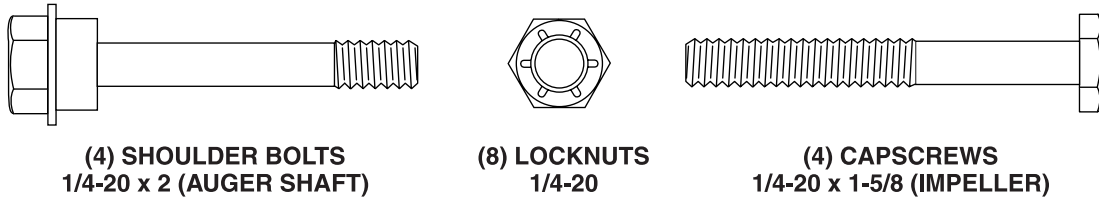

WEIGHT BAG MOUNTING

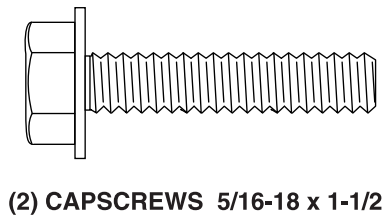

ROTATER HEAD MOUNTING

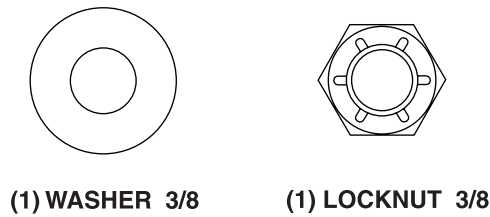

(1) SPRING

CHUTE DEFLECTOR REMOTE CONTROL

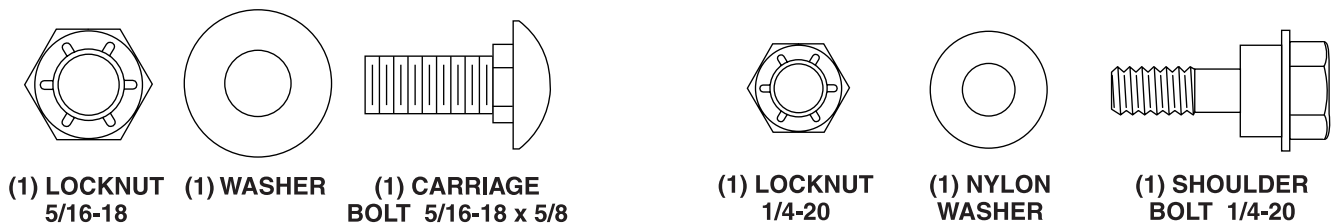

ASSEMBLY

Read these instructions and this manual in its entirety before you attempt to assemble or operate your new snow thrower. Your new snow thrower has been assembled at the factory with the exception of those parts left unassembled for shipping purposes. All parts such as nuts, washers, bolts, etc., necessary to complete the assembly have been placed in the parts bag. To ensure safe and proper operation of your snow thrower, all parts and hardware you assemble must be tightened securely. Use the correct tools as necessary to ensure proper tightness.

REMOVE SNOW THROWER FROM CARTON

1. Remove all accessible loose parts and parts boxes from carton.
2. Cut down all four corners of carton and lay panels flat.
3. Remove all packing materials except plastic tie holding speed control rod to lower handle.
4. Remove snow thrower from carton and check carton thoroughly for additional loose parts.

HOW TO SET UP YOUR SNOW THROWER

TOOL BOX

A toolbox is provided on your snow thrower. The toolbox is located on top of the belt cover. Store the extra shear bolts, nuts and multi-wrench provided in parts bag in the toolbox.

NOTE: The multi-wrench may be used for assembly of the chute rotator head to snow thrower and making adjustments to the skid plates.

UNFOLD UPPER HANDLE

1. Raise upper handle to the operating position and tighten handle knobs securely.

INSTALL SPEED CONTROL ROD

1. Remove plastic tie securing rod to lower handle.
2. Insert rod into speed control bracket and secure with retainer spring.

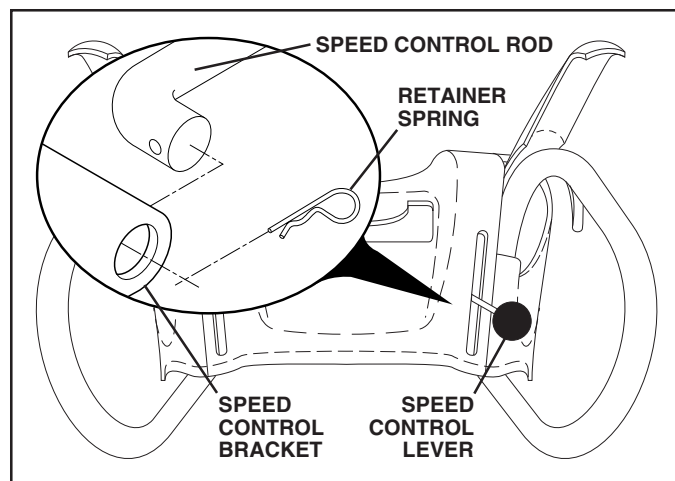

INSTALL TRACTION DRIVE CONTROL ROD

The traction drive control rod has the long loop on the end of the spring as shown.

1. Slide rubber sleeve up rod and hook end of spring into pivot bracket with loop opening down as shown.
2. With top end of rod positioned under left side of control panel, push rod down and insert top end of rod into hole in drive control bracket. Secure with retainer spring.

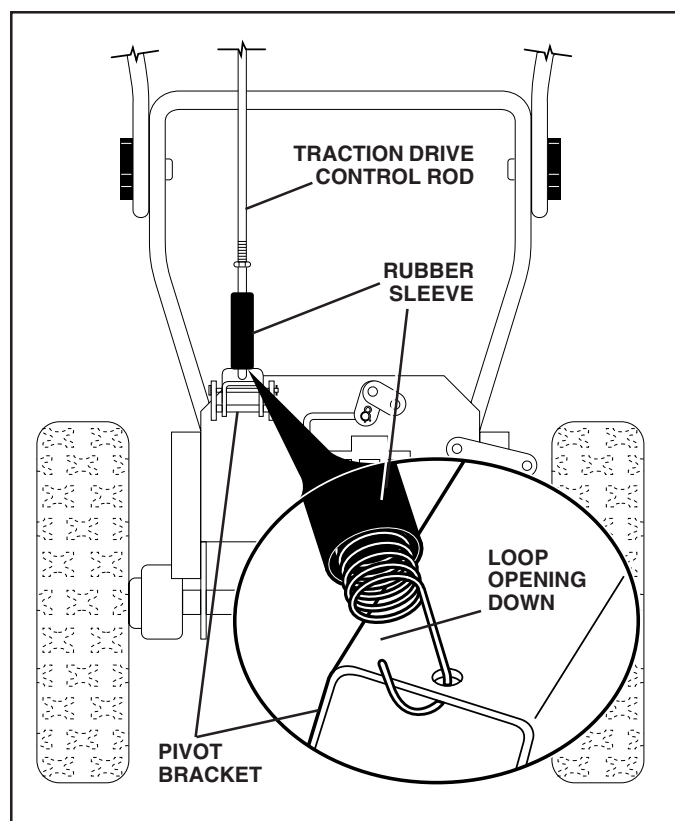
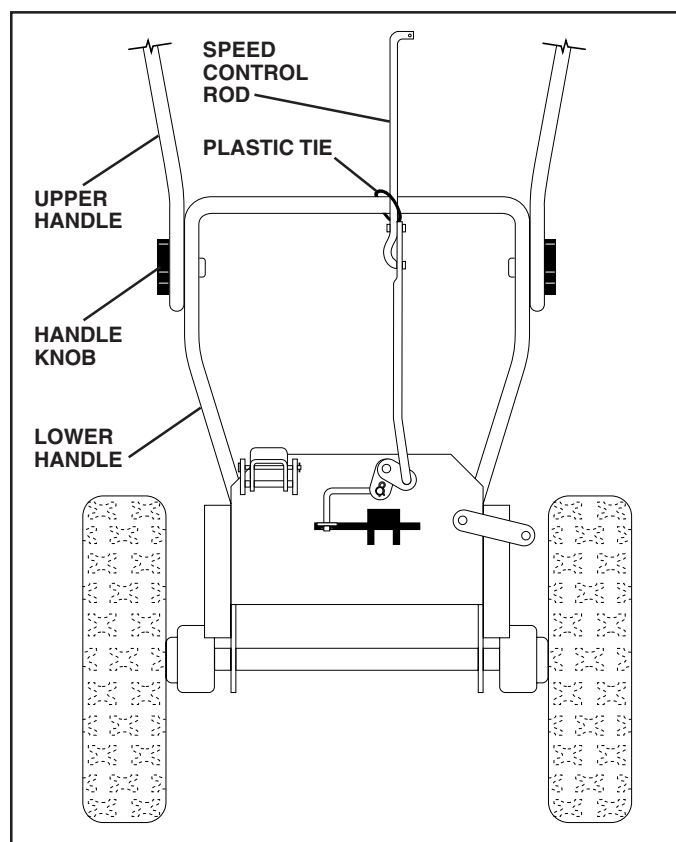

ASSEMBLY

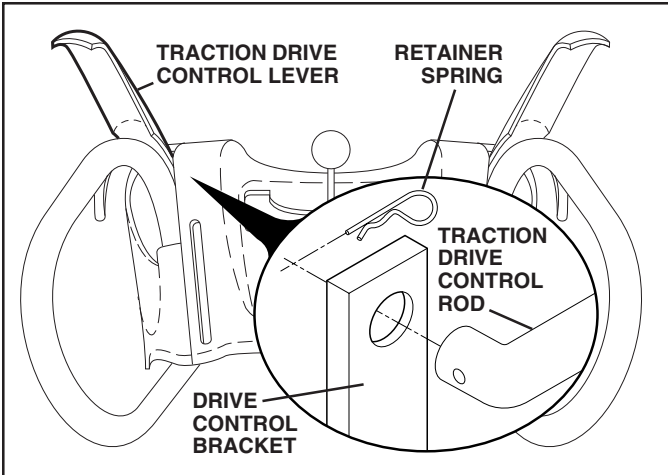

INSTALL AUGER CONTROL ROD

The auger control rod has the short loop on the end of the spring as shown.

1. Slide rubber sleeve up rod and hook end of spring into control arm with loop opening up as shown.
2. With top end of rod positioned under right side of control panel, push down on rod and insert end of rod into hole in auger control bracket. Secure with retainer spring.

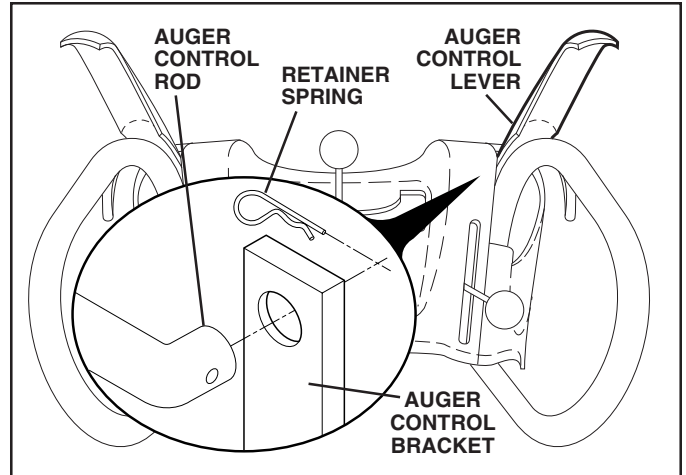
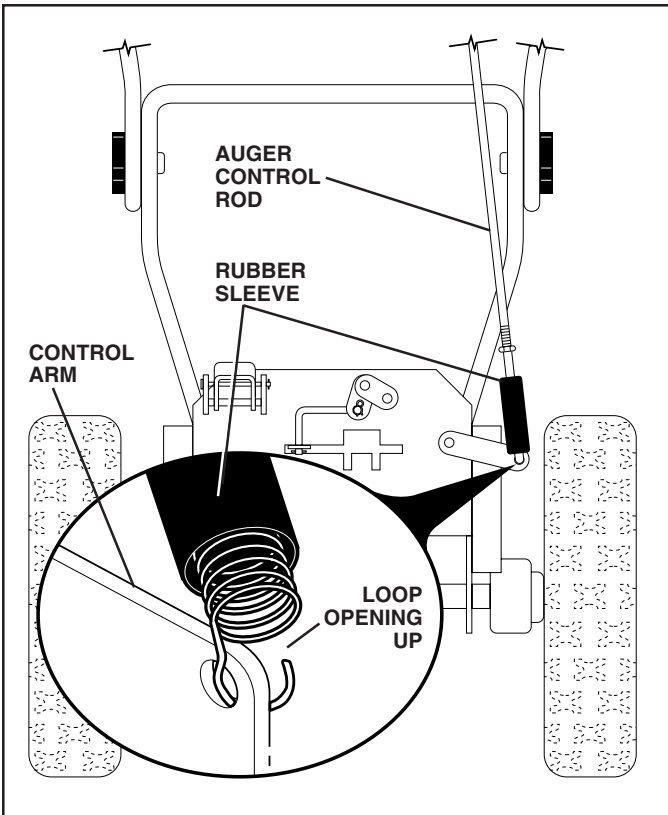

INSTALL DISCHARGE CHUTE/CHUTE ROTATER HEAD

NOTE: The multi-wrench provided in your parts bag may be used to install the chute rotater head.

1. Place discharge chute assembly on top of chute base with discharge opening toward front of snow thrower.
2. Position chute rotater head over chute bracket. If necessary, rotate chute assembly to align square and pin on underside of chute rotater head with holes in chute bracket.
3. With chute rotater head and chute bracket aligned, position chute rotater head on pin and threaded stud of mounting bracket.
4. Install 3/8 washer and locknut on threaded stud and tighten securely.

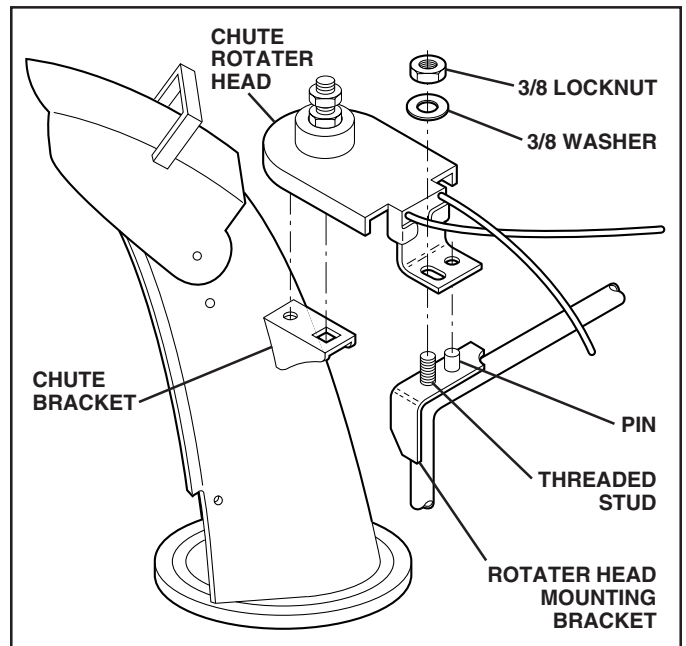

ASSEMBLY

INSTALL CHUTE DEFLECTOR REMOTE CONTROL

1. Install remote cable bracket to discharge chute with 5/16-18 carriage bolt, flat washer and 5/16-18 locknut as shown. Tighten securely.
2. Install remote cable eyelet to chute deflector with 1/4-20 shoulder bolt, nylon washer and 1/4-20 locknut as shown. Tighten securely.
3. Install spring hooks between hex nuts on chute rotater head and into hole in chute deflector as shown.

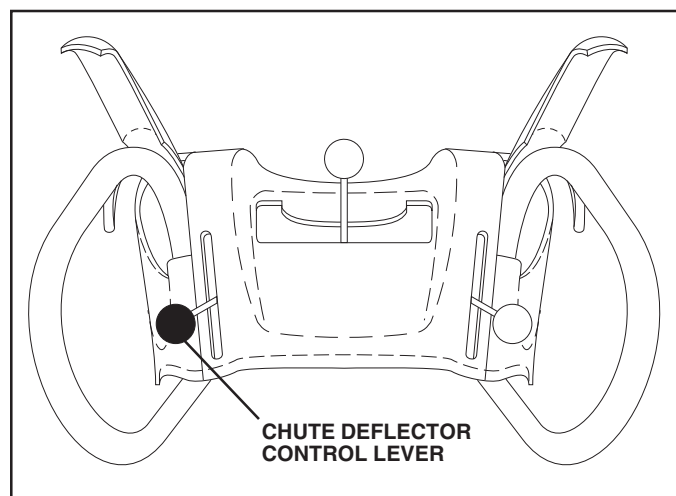
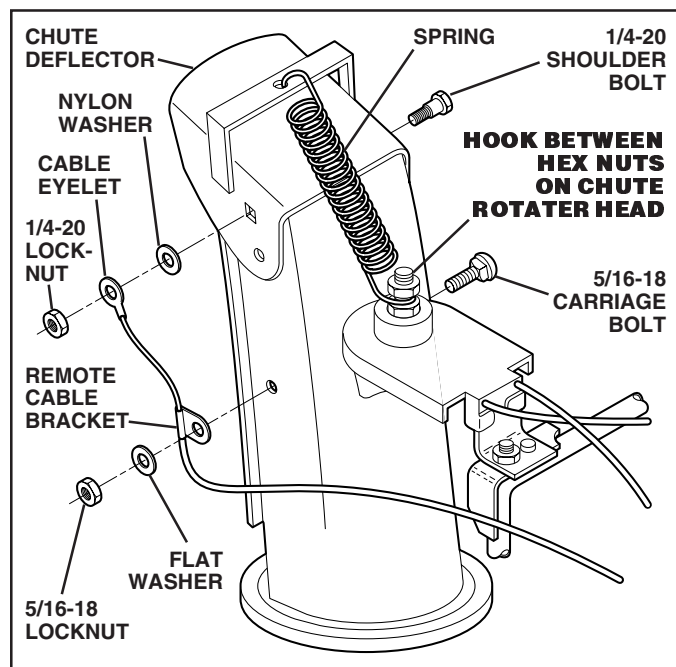

INSTALL WEIGHT BAG

Though seldom required, the weight bag will reduce the tendency of the auger housing to ride up on hard, icy drifts. Should conditions require it, install as follows:

1. Shut off engine and wait for all moving parts to stop.
2. Fill weight bag with desired amount of sand.
3. Place weight bag on top of auger housing with mounting clamp at front edge of auger housing as shown.
4. Insert weight bag between the auger housing and the bar of the mounting clamp as shown and secure with 5/16-18 x 1-1/2 cap screws. Tighten securely.

IMPORTANT: Mount the weight bag in a location which does not cover the warning decals on top of the auger housing.

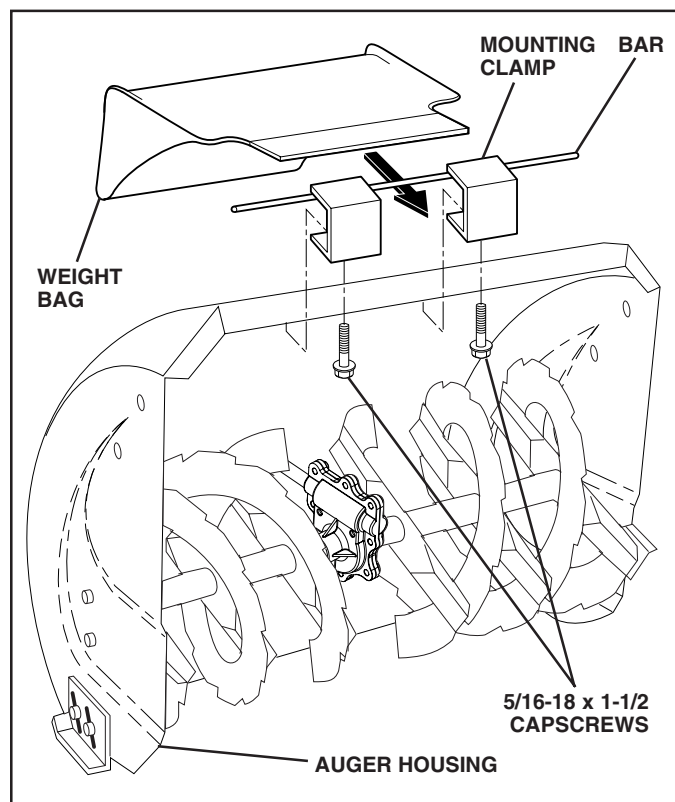

CHECK TIRE PRESSURE

The tires on your snow thrower were overinflated at the factory for shipping purposes. Correct and equal tire pressure is important for best snow throwing performance.

- Reduce tire pressure to 14-17 PSI.

OPERATION

KNOW YOUR SNOW THROWER

READ THIS OWNER'S MANUAL AND ALL SAFETY RULES BEFORE OPERATING YOUR SNOW THROWER. Compare the illustrations with your snow thrower to familiarize yourself with the location of various controls and adjustments. Save this manual for future reference.

These symbols may appear on your snow thrower or in literature supplied with the product. Learn and understand their meaning.

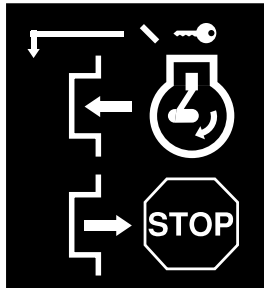
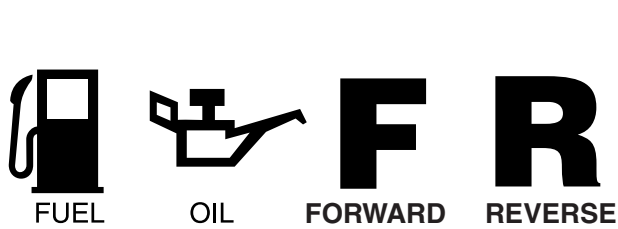

IGNITION KEY.
INSERT TO START
AND RUN,
PULL OUT TO STOP.

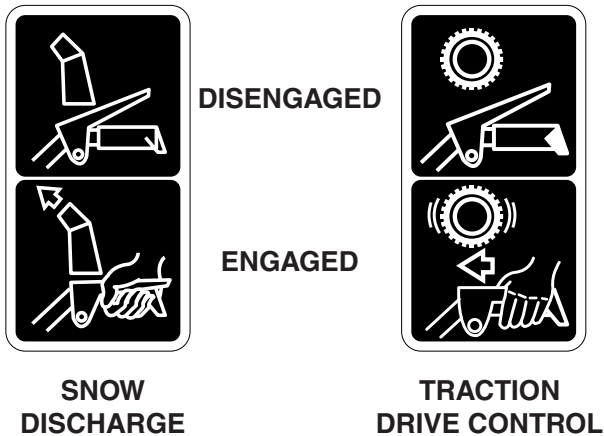

OPERATION

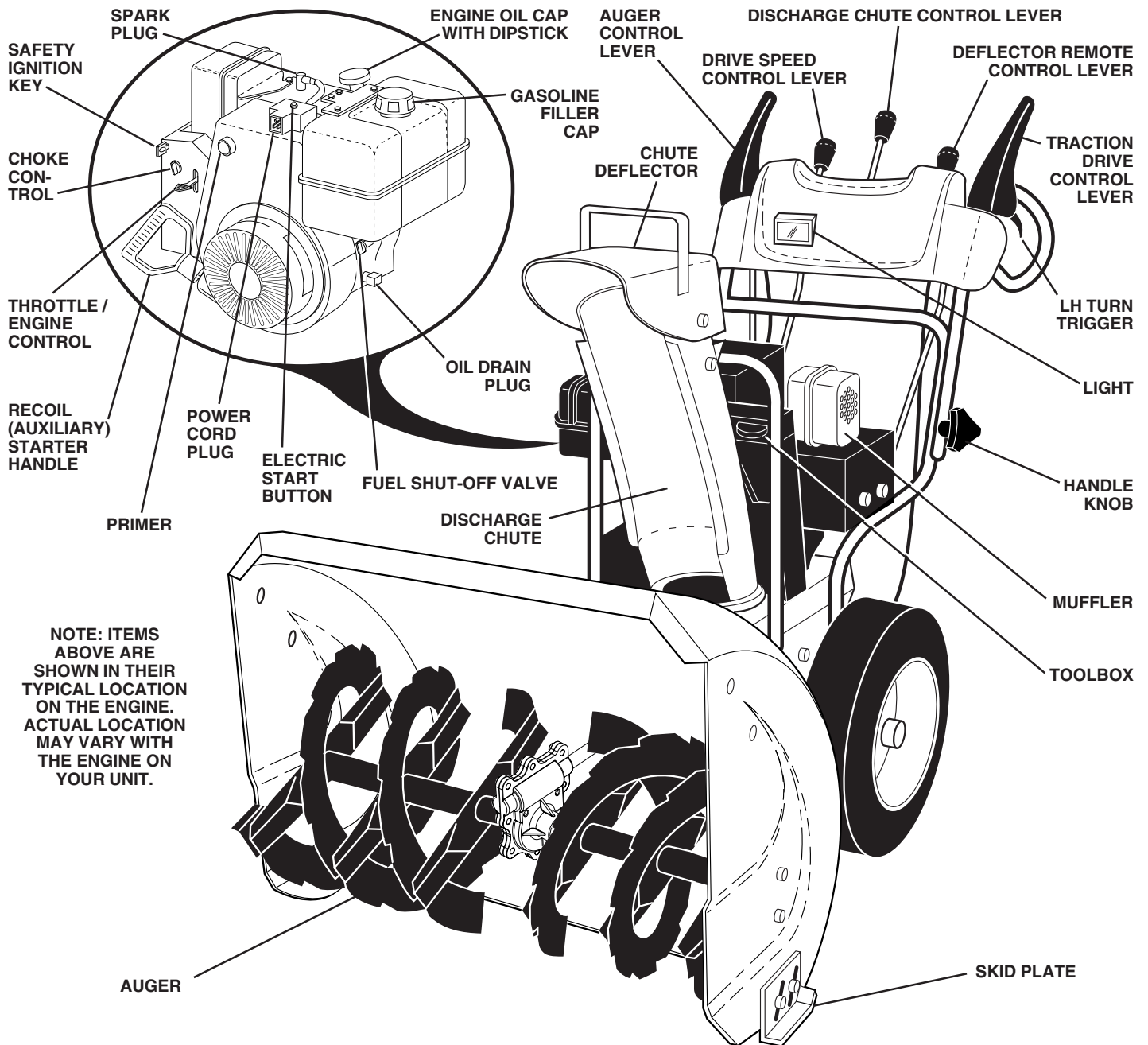

MEETS A.N.S.I. SAFETY REQUIREMENTS

Our snow throwers conform to the standards of the American National Standards Institute.

Toolbox - used to store spare shear bolts, locknuts and wrench.

Safety ignition key - must be inserted for the engine to start and run. Remove when snow thrower is not in use.

Electric start button - used for starting the engine.

Recoil (auxiliary) starter handle - used for starting the engine.

Primer - pumps additional fuel from the carburetor to the cylinder for use when starting a cold engine.

Choke Control - used for starting a cold engine.

Throttle/engine control - used to select either FAST or SLOW engine speed and to STOP the engine.

LH and RH turn triggers - used to steer the snow thrower.

Drive speed control lever - used to select forward or reverse motion and speed of snow thrower.

Traction drive control lever - used to engage power-propelled forward or reverse motion of snow thrower.

Auger control lever - used to engage auger motion (throw snow).

Discharge chute control lever - used to change the direction the snow is thrown.

Deflector remote control lever - used to change the distance the snow is thrown.

Skid plate - used to adjust height of scraper bar from the ground.

OPERATION



The operation of any snow thrower can result in foreign objects thrown into the eyes, which can result in severe eye damage. Always wear safety glasses or eye shields while operating your snow thrower or performing any adjustments or repairs. We recommend standard safety glasses or a wide vision safety mask worn over spectacles.

HOW TO USE YOUR SNOW THROWER

Know how to operate all controls before adding fuel or attempting to start the engine.

STOPPING

TRACTION DRIVE

- Release traction drive control lever to stop the forward or reverse movement of the snow thrower.

AUGER

- Release the auger control lever to stop throwing snow.

ENGINE

- Move throttle control to "STOP" position.
- Remove (do not turn) safety ignition key to prevent unauthorized use.

NOTE: Never use choke to stop engine.

TO USE FUEL SHUT-OFF VALVE

The fuel shut-off valve is located beneath the fuel tank on the engine. Always operate the snow thrower with the fuel shut-off valve in the OPEN position.

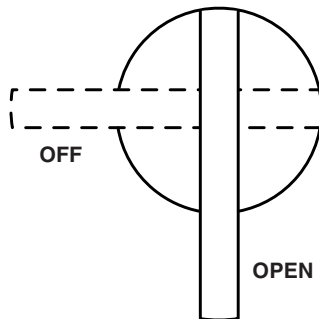

TO USE THROTTLE CONTROL

The throttle control is located on the engine. Always operate the snow thrower with the engine at full throttle. Full throttle offers the best snow thrower performance.

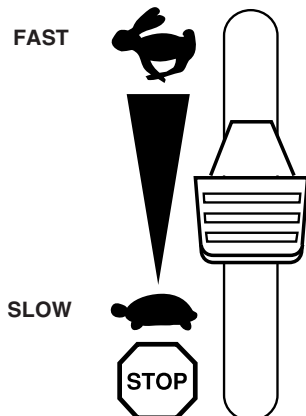

TO USE CHOKE CONTROL

The choke control is located on the engine. Use the choke control whenever you are starting a cold engine. Do not use to start a warm engine.

- To engage choke, turn knob clockwise. Slowly turn knob counterclockwise to disengage.

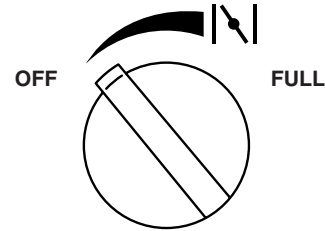

TO CONTROL SNOW DISCHARGE



WARNING: Snow throwers have exposed rotating parts, which can cause severe injury from contact, or from material thrown from the discharge chute. Keep the area of operation clear of all persons, small children and pets at all times including startup.



WARNING: If the discharge chute or auger become clogged, shut-off engine and wait for all moving parts to stop. Use a stick, NOT YOUR HANDS, to unclog the chute and/or auger.

The **DIRECTION** in which snow is to be thrown is controlled by the discharge chute control lever.

- To change the discharge chute position, press downward on discharge chute control lever and move lever left or right until chute is in desired position. Be sure lever springs back and locks into desired position.

The **DISTANCE** that snow is thrown is controlled by the position of the chute deflector. Set the deflector low to throw snow a short distance; set the deflector higher to throw snow farther.

- Press downward on chute deflector control lever and move lever forward to lower the deflector and decrease the distance. Move lever back to raise the deflector and increase the distance. Be sure lever springs back and locks into desired position.

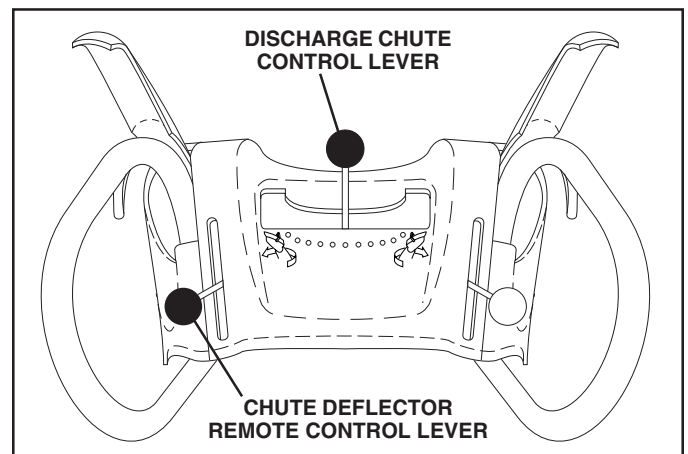

OPERATION

TO THROW SNOW

The auger rotation is controlled by the auger control lever located on the right side handle.

- Squeeze auger control lever to handle to engage the auger and throw snow.
- Release the auger control lever to stop throwing snow.

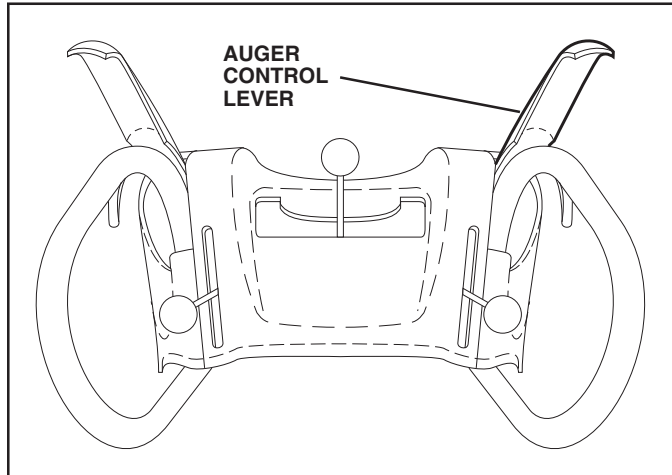

TO MOVE FORWARD AND BACKWARD

SELF-PROPELLING, forward and reverse movement of the snow thrower, is controlled by the traction drive control lever located on the left side handle.

- Squeeze traction drive control lever to handle to engage the drive system.
- Release traction drive control lever to stop the forward or reverse movement of the snow thrower.

SPEED and DIRECTION are controlled by the drive speed control lever.

- Press downward on the speed control lever and move lever to desired position BEFORE engaging the traction drive control lever. Be sure lever springs back and locks into desired position.

CAUTION: Do not move speed control lever when traction drive control lever is engaged. Damage to the snow thrower can result.

- Slower speeds are for heavier snow and faster speeds are for light snow and transporting the snow thrower. It is recommended that you use a slower speed until you are familiar with the operation of the snow thrower.

NOTE: When both traction drive and auger control levers are engaged, the traction drive control lever will lock the auger control lever in the engaged position. This will allow you to release your right hand from the handle and adjust the discharge chute direction without interrupting the snow throwing process.

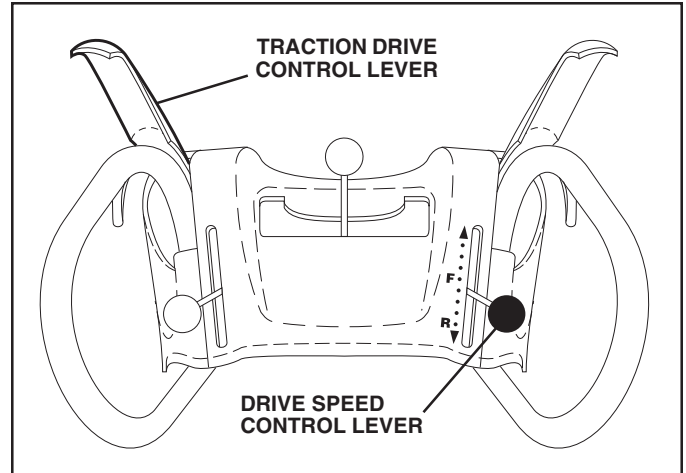

POWER STEERING OPERATION

Steering triggers are used to assist in steering your snow thrower. The triggers are located on the underside of each handle. When a trigger is squeezed, it disengages the drive wheel on that side of snow thrower and allows it to turn in that direction.

- To turn left – squeeze left side trigger.
- To turn right – squeeze right side trigger.

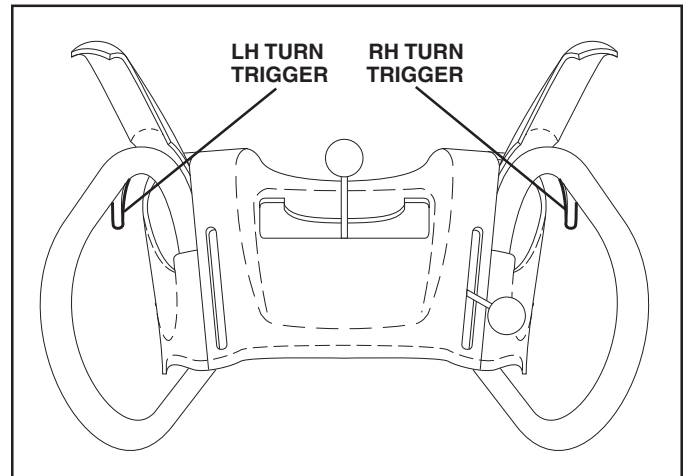

OPERATION

TO ADJUST SKID PLATES

NOTE: The wrench provided in your parts bag may be used to adjust the skid plates.

Skid plates are located on each side of the auger housing and adjust the clearance between the scraper bar and the ground surface. Adjust skid plates evenly to proper height for current surface conditions. For removal of snow in normal conditions, such as a paved driveway or sidewalk, place skid plates in the highest position (lowest scraper clearance) to give a 1/8" clearance between the scraper bar and the ground. Use a middle position if the surface to be cleared is uneven.

NOTE: It is not recommended to operate the snow thrower over gravel or rocky surfaces. Objects such as gravel, rocks or other debris, can easily be picked up and thrown by the impeller, which can cause serious personal injury, property damage or damage to the snow thrower.

- If snow thrower must be operated over gravel surface, use extra caution and be sure skid plates are adjusted to lowest (highest scraper clearance) position.
1. Shut off engine and wait for all moving parts to stop.
 2. Adjust skid plates by loosening the rear 1/2" hex nut only, then moving skid plate to desired position. Be sure both plates are adjusted evenly. Tighten securely.

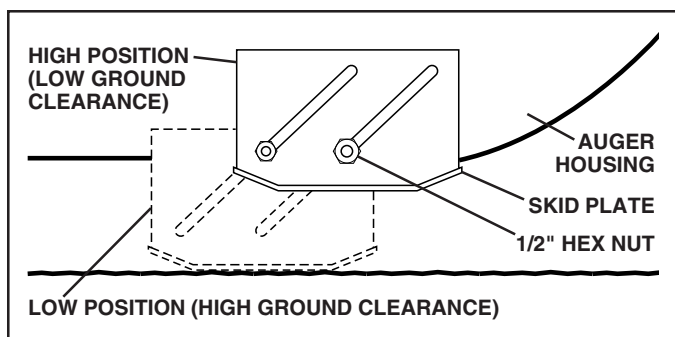

SCRAPER BAR

The scraper bar is not adjustable, but is reversible. After considerable use it may become worn. When it has worn almost to the edge of the housing, it can be reversed, providing additional service before requiring replacement. Replace a damaged or worn scraper bar.

BEFORE STARTING THE ENGINE

CHECK ENGINE OIL LEVEL

The engine on your snow thrower has been shipped, from the factory, already filled with oil.

1. Check engine oil with snow thrower on level ground.
 2. Remove oil fill cap/dipstick and wipe clean, reinsert the dipstick and screw tight, wait for a few seconds, remove and read oil level. If necessary, add oil until "FULL" mark on dipstick is reached. Do not overfill.
- To change engine oil, see "TO CHANGE ENGINE OIL" in the Maintenance section of this manual.

ADD GASOLINE

- Fill fuel tank to bottom of tank filler neck. Do not overfill. Use fresh, clean, regular unleaded gasoline with a minimum of 87 octane. Do not mix oil with gasoline. Purchase fuel in quantities that can be used within 30 days to assure fuel freshness.



WARNING: Wipe off any spilled oil or fuel. Do not store, spill or use gasoline near an open flame.

CAUTION: Alcohol blended fuels (called gasohol or using ethanol or methanol) can attract moisture which leads to separation and formation of acids during storage. Acidic gas can damage the fuel system of an engine while in storage. To avoid engine problems, the fuel system should be emptied before storage of 30 days or longer. Drain the gas tank, start the engine and let it run until the fuel lines and carburetor are empty. Use fresh fuel next season. See Storage Instructions for additional information. Never use engine or carburetor cleaner products in the fuel tank or permanent damage may occur.

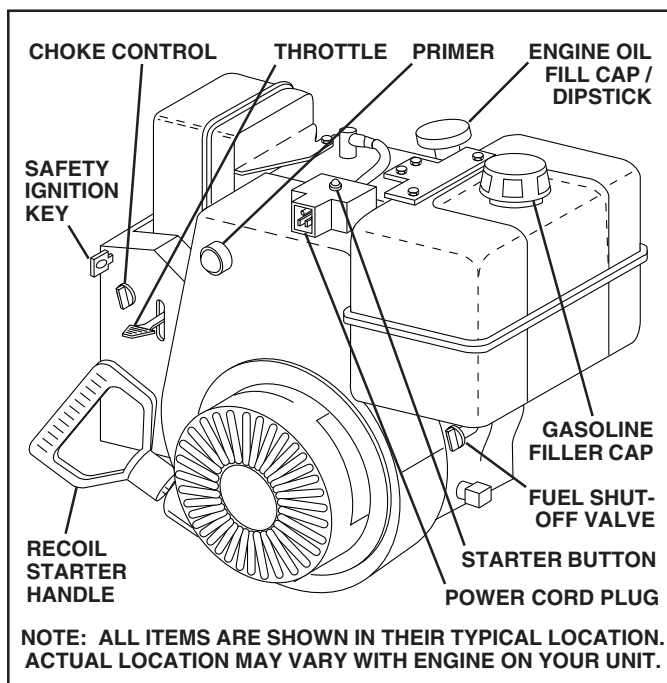

TO START ENGINE

- Be sure fuel shut-off valve is in the OPEN position.

Your snow thrower engine is equipped with both a 120 Volt A.C. electric starter and a recoil starter. The electric starter is equipped with a three-wire power cord and plug and is designed to operate on 120 Volt A.C. household current.

- Be sure your house is a 120 Volt A.C. three-wire grounded system. If you are uncertain, consult a licensed electrician.



WARNING: Do not use the electric starter if your house is not a 120 Volt A.C. three-wire grounded system. Serious personal injury or damage to your snow thrower could result.

OPERATION

COLD START - ELECTRIC STARTER

1. Insert safety ignition key into the ignition slot until it clicks. **DO NOT** turn the key. Keep the extra safety ignition key in a safe place.
2. Place throttle control in FAST position.
3. Rotate choke control to FULL position.
4. Connect the power cord to the engine.
5. Plug the other end of the power cord into a three-hole grounded 120 Volt A.C. receptacle.

NOTE: Do not use primer when starting engine with the electric starter.

6. Push starter button until engine starts.

IMPORTANT: Do not crank engine more than five continuous seconds between each time you try to start. Wait 5 to 10 seconds between each attempt.

7. When the engine starts, release the starter button and slowly move the choke control to the OFF position.
8. Disconnect the power cord from the receptacle first, then from the engine.

Allow the engine to warm up for a few minutes. Engine will not develop full power until it has reached normal operating temperature.

WARM START - ELECTRIC STARTER

Follow the steps above, keeping the choke control in the OFF position.

COLD START - RECOIL STARTER

1. Insert safety ignition key into the ignition slot until it clicks. **DO NOT** turn the key. Keep the extra safety ignition key in a safe place.
2. Place throttle control in FAST position.
3. Rotate choke control to FULL position.
4. Push the primer four (4) times if the temperature is below 15°F, or two (2) times if temperature is between 15° and 50°F. If temperature is above 50°F, priming is not necessary.

NOTE: Over priming may cause flooding, preventing the engine from starting. If you do flood the engine, wait a few minutes before attempting to start and **DO NOT** push the primer.

5. Pull recoil starter handle quickly. Do not allow starter rope to snap back.
6. When the engine starts, release the recoil starter handle and slowly move the choke control to the OFF position.

Allow the engine to warm up for a few minutes. Engine will not develop full power until it has reached normal operating temperature.

WARM START - RECOIL STARTER

Follow the steps above, keeping the choke in the OFF position. **DO NOT** push the primer.

BEFORE STOPPING

Run the engine for a few minutes to help dry off any moisture on the engine.

To avoid possible freeze-up of the starter, proceed as follows:

ELECTRIC STARTER

1. Connect the power cord to the engine.
2. Plug the other end of the power cord into a three-hole grounded 120 Volt A.C. receptacle.
3. While the engine is running, push starter button and spin the starter for several seconds.

NOTE: The unusual sound made while starter is spinning will not harm the engine or starter.

4. Disconnect the power cord from the receptacle first, then from the engine.

RECOIL STARTER

1. While the engine is running, pull the recoil starter handle with rapid, full arm strokes three or four times.

NOTE: The unusual sound made while pulling the recoil starter handle will not harm the engine or starter.

IF RECOIL STARTER HAS FROZEN

If the recoil starter has frozen and will not turn the engine, proceed as follows:

1. Grasp the recoil starter handle and slowly pull as much rope out of the starter as possible.
2. Release the recoil starter handle and let it snap back against the starter.

If the engine still fails to start, repeat the above steps or use the electric starter.

SNOW THROWING TIPS

- Always operate the snow thrower with the engine at full throttle. Full throttle offers the best performance.
- Go slower in deep, freezing or heavy wet snow. Use the drive speed control, **NOT** the throttle, to adjust speed.
- It is easier and more efficient to remove snow immediately after it falls.
- The best time to remove snow is the early morning. At this time the snow is usually dry and has not been exposed to the direct sun and warming temperatures.
- Slightly overlap each successive path to ensure all snow will be removed.
- Throw snow downwind whenever possible.
- Adjust the skid plates to proper height for current snow conditions. See "TO ADJUST SKID PLATES" in this section of this manual.
- For extremely heavy snow, reduce the width of snow removal by overlapping previous path and moving slowly.
- Keep engine clean and clear of snow during use. This will help air flow and extend engine life.
- After snow-throwing is completed, allow engine to run for a few minutes to melt snow and ice off the engine.
- Clean the entire snow thrower thoroughly after each use and wipe dry so it is ready for next use.



WARNING: Do not operate snow thrower if weather conditions impair visibility. Throwing snow during a heavy, windy snowstorm can blind you and be hazardous to the safe operation of the snow thrower.

MAINTENANCE

V-BELTS

Check V-belts for deterioration and wear after every 50 hours of operation and replace if necessary. The belts are not adjustable. Replace belts if they begin to slip from wear. (See "TO REMOVE BELT COVER" in the Service and Adjustments section of this manual).

The V-belts on your snow thrower are of special construction and should be replaced by original equipment manufacturer (OEM) belts available from your nearest dealer. Using other than OEM belts can cause personal injury or damage to the snow thrower.

AUGER GEAR CASE

- The gear case was filled with lubricant to the proper level at the factory. The only time the lubricant needs attention is if service has been performed on the gear case.
- If lubricant is required, use only Ronex ED #1 grease.

TRACTION DRIVE SYSTEM

DO NOT lubricate the drive components inside the snow thrower. The sprockets, hex shafts, drive disc and friction wheel require no lubrication. The bearings and bushings are lifetime lubricated and require no maintenance.

CAUTION: Any lubricating of the above components can cause contamination of the friction wheel and damage to the drive system of your snow thrower.

ENGINE

See engine manual.

LUBRICATION

Use only high quality detergent oil rated with API service classification SF-SJ. Select the oil's SAE viscosity grade according to your expected operating temperature.

NOTE: Although multi-viscosity oils (5W30, 10W30 etc.) improve starting in cold weather, these multi-viscosity oils will result in increased oil consumption when used above 32°F. Check your engine oil level more frequently to avoid possible engine damage from running low on oil.

Change the oil after every 50 hours of operation or at least once a year if the snow thrower is not used for 50 hours in one year.

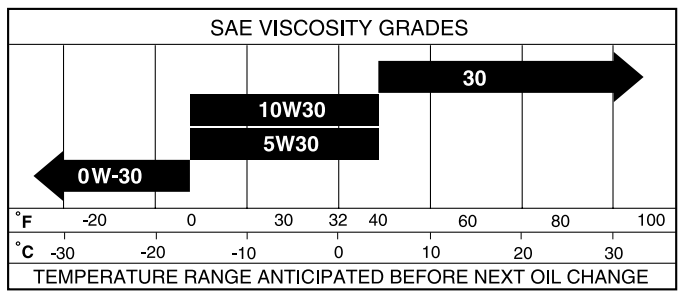

Check the crankcase oil level before starting the engine and after each five (5) hours of continuous use. Tighten oil fill cap / dipstick securely each time you check the oil level.

TO CHANGE ENGINE OIL

Determine temperature range anticipated before next oil change. All oil must meet API service classification SF-SJ.

- Be sure snow thrower is on level surface.
- Oil will drain more freely when warm.
- Catch oil in a suitable container.

NOTE: The left side wheel may be removed from snow thrower for easier access to the oil drain plug and placement of a suitable container. The unit tilted, resting on the frame with the left wheel removed, will help drain any oil trapped inside the engine. (See "TO REMOVE WHEELS" in the Service and Adjustments section of this manual).

1. Disconnect spark plug wire from spark plug and place wire where it cannot come in contact with spark plug.
2. Clean area around drain plug.
3. Remove drain plug and drain oil in a suitable container.
4. Install drain plug and tighten securely.
5. Wipe off any spilled oil from snow thrower and engine.
6. Install left wheel (if removed for draining oil). Be sure to install click pin into proper hole in wheel axle (See "TO REMOVE WHEELS" in the Service and Adjustments section of this manual).
7. Remove oil fill cap/dipstick. Be careful not to allow dirt to enter the engine.
8. Refill engine with oil through oil dipstick tube. Pour slowly. Do not overfill. For approximate capacity see "PRODUCT SPECIFICATIONS" section of this manual.
9. Use gauge on oil fill cap/dipstick for checking level. Be sure dipstick cap is tightened securely for accurate reading. Keep oil at "FULL" line on dipstick.
10. Wipe off any spilled oil.

MUFFLER

Inspect and replace corroded muffler as it could create a fire hazard and/or damage.

SPARK PLUG

Replace spark plug at the beginning of each season or after every 100 hours of operation, whichever occurs first. Spark plug type and gap setting are shown in the "PRODUCT SPECIFICATIONS" section of this manual.

CLEANING

IMPORTANT: For best performance, keep snow thrower housing free of any dirt or trash. Clean the outside of your snow thrower after each use.

WARNING: Disconnect spark plug wire from spark plug and place wire where it cannot come in contact with spark plug.

- Keep finished surfaces/wheels free of gasoline, oil, etc.
- We do not recommend using a garden hose to clean your snow thrower unless the electrical system, muffler and carburetor are covered to keep water out. Water in engine can result in shortened engine life.

SERVICE AND ADJUSTMENTS

WARNING: To avoid serious injury, before performing any service or adjustments:



1. Be sure throttle is in STOP position.
2. Remove safety ignition key.
3. Make sure the augers and all moving parts have completely stopped.
4. Disconnect spark plug wire from spark plug and place wire where it cannot come in contact with plug.

SNOW THROWER

TO ADJUST SNOW THROWER HEIGHT

See "TO ADJUST SKID PLATES" and "SCRAPER BAR" in the Operation section of this manual.

CHUTE DEFLECTOR

The chute deflector, attached to the top of the discharge chute, is provided to direct discharging snow away from the operator. If the deflector becomes damaged, it should be replaced.



WARNING: To avoid serious injury, never operate your snow thrower with the deflector removed or damaged.

- To change direction and/or distance snow is discharged, see "TO CONTROL SNOW DISCHARGE" in the Operation section of this manual.

SHEAR BOLTS

AUGER SHEAR BOLTS

Both right and left-hand augers are secured to the auger shaft with a shoulder/shear bolt and hex nut. Should a foreign object or ice become lodged in the augers, the shear bolts are designed to break, preventing damage to any other components. If one or both augers do not turn when auger control lever is engaged, check to see if one or both of the bolts have sheared. To replace the shear bolts:

1. Disengage all controls and move throttle control to STOP position. Wait for all moving parts to stop.
2. Disconnect spark plug wire from spark plug and place it where it cannot come in contact with spark plug.
3. Align hole in auger hub with hole in auger shaft and install a new 1/4-20 x 2" shoulder/shear bolt. Install 1/4-20 lock nut and tighten securely.

CAUTION: Do not substitute. Use only original equipment shear bolts as supplied with your snow thrower.

4. Connect spark plug wire to spark plug.

IMPELLER SHEAR BOLTS

The impeller is secured to the impeller shaft with two (2) capscrew/shear bolts and hex nuts. Should a foreign object or ice become lodged in the impeller, the capscrews are designed to break, preventing damage to any other components. If impeller does not turn when auger control lever is engaged, check to see if the capscrews have sheared. To replace the capscrew/shear bolts:

1. Disengage all controls and move throttle control to STOP position. Wait for all moving parts to stop.
2. Disconnect spark plug wire from spark plug and place it where it cannot come in contact with spark plug.
3. Align holes in impeller hub with holes in impeller shaft and install two (2) new 1/4-20 x 1-5/8" capscrew/shear bolts. Install 1/4-20 locknuts and tighten securely.

CAUTION: Do not substitute. Use only original equipment capscrew/shear bolts as supplied with your snow thrower.

4. Connect spark plug wire to spark plug.

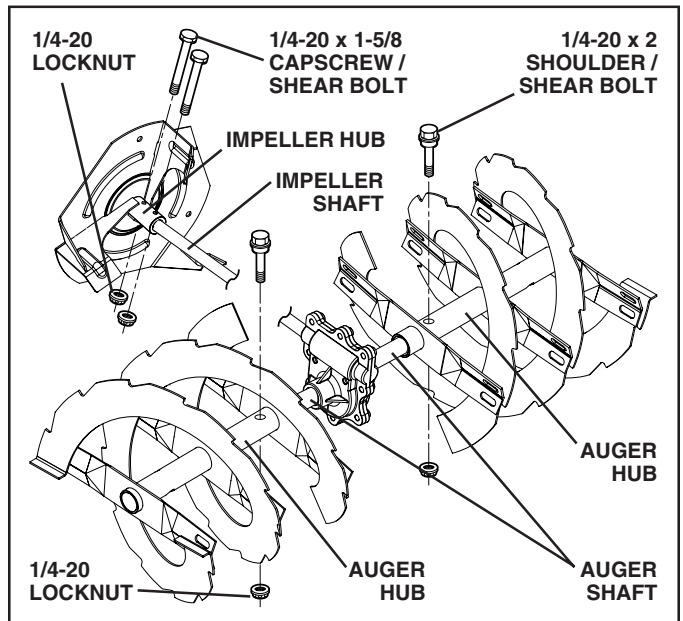

TO REMOVE BELT COVER

1. Remove the two (2) screws securing belt cover to frame.
 2. Remove belt cover.
- Replace belt cover by installing cover and screws and tighten securely.

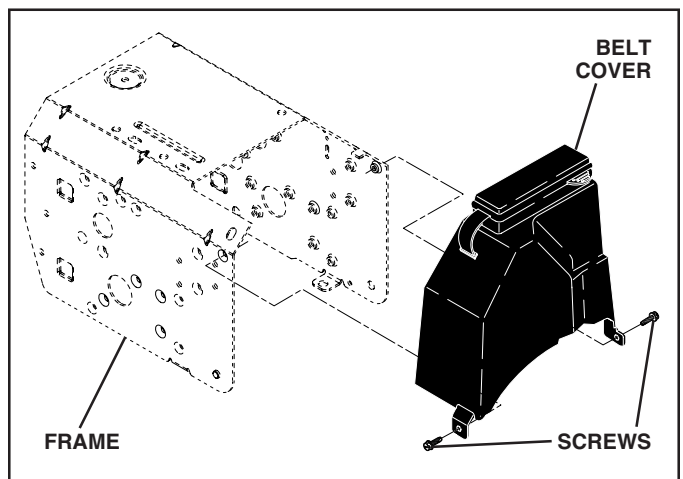

SERVICE AND ADJUSTMENTS

TO REPLACE BELTS

The auger and traction drive belts are not adjustable. If the belts are damaged or begin to slip from wear, they should be replaced. It is recommended that the belt(s) be replaced by a qualified service center.

NOTE: It is recommended that both the auger and traction drive belt be replaced at the same time.

The V-belts on your snow thrower are of special construction and should be replaced by original equipment manufacturer (OEM) belts available from your nearest dealer. Using other than OEM belts can cause personal injury or damage to the snow thrower.

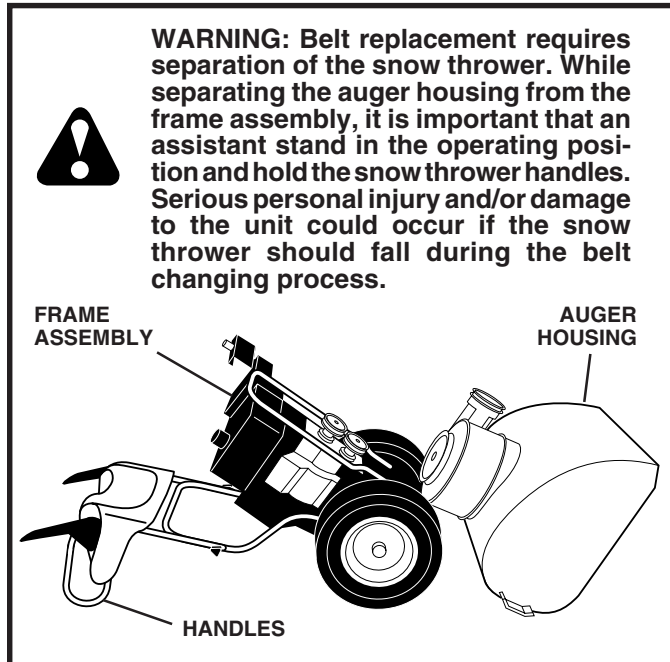

1. REMOVE GASOLINE FROM FUEL TANK - Drain gasoline from fuel tank into a suitable container, outdoors, away from fire or flame. Wipe up any spilled gasoline.
2. REMOVE DISCHARGE CHUTE - Loosen locknut securing chute rotator head to mounting bracket only enough to allow chute rotator head to be raised and discharge chute to be removed from snow thrower.
3. REMOVE BELT COVER - See "TO REMOVE BELT COVER" in this section of this manual.
4. REMOVE ENGINE PULLEY - Remove bolt, lockwasher and flat washer securing pulley to engine crankshaft. Remove outside (auger) pulley only from crankshaft.
5. SEPARATE SNOW THROWER - With your assistant standing in the operating position holding the handles, remove the two (2) bolts and lock washers holding auger housing and frame together.



6. REMOVE AUGER BELT from around pulley.
7. RELIEVE TENSION ON TRACTION DRIVE BELT IDLER and remove traction drive belt from around pulleys.

HINT: Insert a 3/8" drive ratchet (in the "ON" position) into the square hole in idler arm and rotate ratchet clockwise to relieve tension.

8. With tension relieved on idler, install new traction drive belt around pulleys and inside belt keepers.
9. Place auger belt around and inside the groove of auger pulley only.
10. While your assistant slowly raises handles to rejoin the auger housing and frame assembly, pull up on the auger belt and squeeze sides together above pulley so belt is fully seated in groove of pulley.
11. Bring snow thrower completely together and check carefully for proper routing of belts. If auger belt has become dislodged from the pulley (by catching the idler arm bracket while bringing snow thrower together), separate the snow thrower and repeat step 10. Belt must be fully seated in pulley groove when bringing the snow thrower together.
12. Install the two (2) hex bolts and lock washers and tighten securely.
13. INSTALL ENGINE PULLEY - Place belt in pulley groove and slide pulley on crankshaft. Install flat washer, lockwasher and bolt and tighten securely (30-35 ft. lbs. torque). Make sure belt is inside belt keeper.
14. INSTALL BELT COVER and two (2) screws. Tighten securely.
15. INSTALL DISCHARGE CHUTE - See "INSTALL DISCHARGE CHUTE / CHUTE ROTATER HEAD" in the Assembly section of this manual.

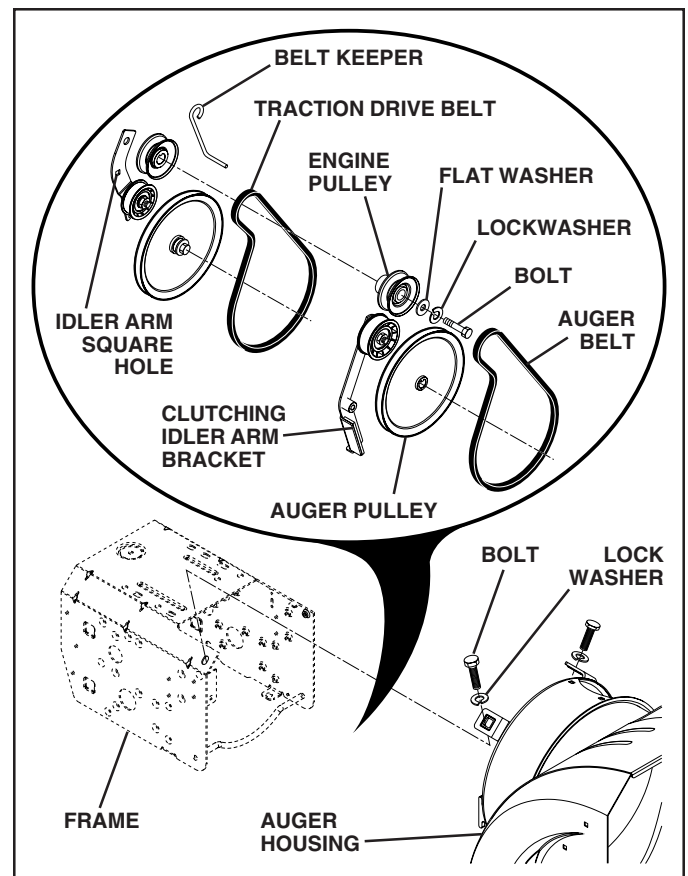

TO REMOVE WHEELS

- Remove the klik pin and remove wheel from axle.

IMPORTANT: When installing wheel, be sure to use the axle hole closest to the end of the shaft - *do not* use the hole in the wheel hub (if equipped). Inner hole in axle and hole in wheel hub are not used for your model snow thrower.

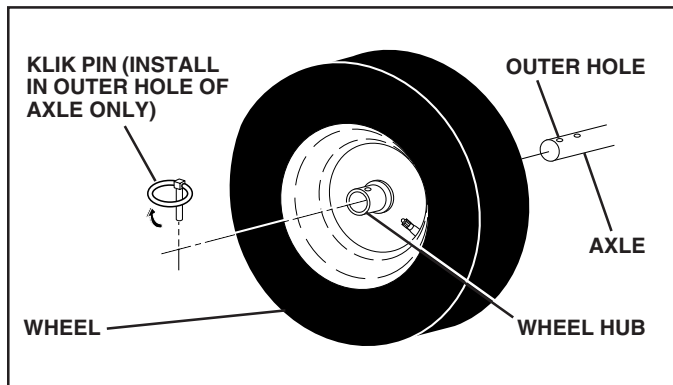

NOTE: To seal punctures or prevent flat tires due to slow leaks, tire sealant may be purchased from your local parts dealer. Tire sealant also prevents tire dry rot and corrosion.

ENGINE

See engine manual.

CARBURETOR

Your carburetor is not adjustable. Engine performance should not be affected at altitudes up to 7,000 feet (2,134 meters). If your engine does not operate properly due to suspected carburetor problems, take your snow thrower to a qualified service center.

ENGINE SPEED

Never tamper with the engine governor, which is factory set for proper engine speed. Overspeeding the engine above the factory high speed setting can be dangerous and will void the warranty. If you think the engine-governed high speed needs adjusting, contact a qualified service center, which has proper equipment and experience to make any necessary adjustments.

STORAGE

Immediately prepare your snow thrower for storage at the end of the season or if the unit will not be used for 30 days or more.



WARNING: Never store the snow thrower with gasoline in the tank inside a building where fumes may reach an open flame, spark or pilot light as on a furnace, water heater, clothes dryer or gas appliance. Allow the engine to cool before storing in any enclosure.

SNOW THROWER

When snow thrower is to be stored for a period of time, clean it thoroughly, remove all dirt, grease, leaves, etc. Store in a clean, dry area.

- Clean entire snow thrower (See "CLEANING" in the Maintenance section of this manual).
- Inspect and replace belts, if necessary (See "TO REPLACE BELTS" in the Service and Adjustments section of this manual).
- Lubricate as shown in the Maintenance section of this manual.
- Be sure that all nuts, bolts, screws, and pins are securely fastened. Inspect moving parts for damage, breakage and wear. Replace if necessary.
- Touch up all rusted or chipped paint surfaces; sand lightly before painting.

ENGINE

See engine manual.

FUEL SYSTEM

IMPORTANT: It is important to prevent gum deposits from forming in essential fuel system parts such as carburetor, fuel hose, or tank during storage. Also, alcohol blended fuels (called gasohol or using ethanol or methanol) can attract moisture which leads to separation and formation of acids during storage. Acidic gas can damage the fuel system of an engine while in storage.

- Drain the fuel tank.
- Start the engine and let it run until the fuel lines and carburetor are empty.
 - Never use engine or carburetor cleaner products in the fuel tank or permanent damage may occur.
 - Use fresh fuel next season.

NOTE: Fuel stabilizer is an acceptable alternative in minimizing the formation of fuel gum deposits during storage. Add stabilizer to gasoline in fuel tank or storage container. Always follow the mix ratio found on stabilizer container. Run engine at least 10 minutes after adding stabilizer to allow the stabilizer to reach the carburetor. Do not drain the gas tank and carburetor if using fuel stabilizer.

ENGINE OIL

Drain oil (with engine warm) and replace with clean engine oil. (See "ENGINE" in the Maintenance section of this manual).

CYLINDER

- Remove spark plug.
- Pour one ounce (29 ml) of oil through spark plug hole into cylinder.
- Pull recoil starter handle slowly a few times to distribute oil.
- Replace with new spark plug.

OTHER

- Do not store gasoline from one season to another.
- Replace your gasoline can if your can starts to rust. Rust and/or dirt in your gasoline will cause problems.
- If possible, store your snow thrower indoors and cover it to protect it from dust and dirt.
- Cover your snow thrower with a suitable protective cover that does not retain moisture. Do not use plastic. Plastic cannot breathe, which allows condensation to form and will cause your snow thrower to rust.

IMPORTANT: Never cover snow thrower while engine/exhaust area is still warm.

TROUBLESHOOTING

See appropriate section in manual unless directed to a qualified service center.

PROBLEM	CAUSE	CORRECTION
Does not start	<ol style="list-style-type: none"> 1. Fuel shut-off valve (if so equipped) in OFF position. 2. Safety ignition key is not inserted. 3. Out of fuel. 4. Throttle in STOP position. 5. Choke in OFF position. 6. Primer not depressed. 7. Engine is flooded. 8. Spark plug wire is disconnected. 9. Bad spark plug. 10. Stale fuel. 11. Water in fuel. 	<ol style="list-style-type: none"> 1. Turn fuel shut-off valve to OPEN position. 2. Insert safety ignition key. 3. Fill fuel tank. 4. Move throttle to FAST position. 5. Move to FULL position. 6. Prime as instructed in the Operation section of this manual. 7. Wait a few minutes before restarting, DO NOT prime. 8. Connect wire to spark plug. 9. Replace spark plug. 10. Drain fuel tank and carburetor, refill tank with fresh gasoline. 11. Drain fuel tank and carburetor, refill tank with fresh gasoline.
Loss of power	<ol style="list-style-type: none"> 1. Spark plug wire loose. 2. Throwing too much snow. 3. Fuel tank cap is clogged with ice or snow. 4. Dirty or clogged muffler. 	<ol style="list-style-type: none"> 1. Reconnect spark plug wire. 2. Reduce speed and width of swath. 3. Remove ice and snow on and around fuel tank cap. 4. Clean or replace muffler.
Engine idles or runs roughly	<ol style="list-style-type: none"> 1. Choke is in FULL position. 2. Blockage in fuel line. 3. Stale fuel. 4. Water in fuel. 5. Carburetor is in need of adjustment or overhaul. 	<ol style="list-style-type: none"> 1. Move choke to OFF position. 2. Clean fuel line. 3. Drain tank and refill with fresh, clean fuel. 4. Drain fuel tank and carburetor, refill tank with fresh gasoline. 5. Contact a qualified service center.
Excessive vibration	<ol style="list-style-type: none"> 1. Loose parts or damaged augers or impeller. 	<ol style="list-style-type: none"> 1. Tighten all fasteners. Replace damaged parts. If vibration remains, contact a qualified service center.
Recoil starter is hard to pull	<ol style="list-style-type: none"> 1. Frozen recoil starter. 	<ol style="list-style-type: none"> 1. See "If Recoil Starter Has Frozen" in the Operation section of this manual.
Loss of traction drive / slowing of drive speed	<ol style="list-style-type: none"> 1. Drive belt is worn. 2. Drive belt is off of pulley. 3. Friction drive wheel is worn. 	<ol style="list-style-type: none"> 1. Check / replace drive belt. 2. Check / reinstall drive belt. 3. Contact a qualified service center.
Loss of snow discharge or slowing of snow discharge	<ol style="list-style-type: none"> 1. Auger belt is off of pulley. 2. Auger belt is worn. 3. Clogged discharge chute. 4. Augers / impeller jammed. 	<ol style="list-style-type: none"> 1. Check / reinstall auger belt. 2. Check / replace auger belt. 3. Clean snow chute. 4. Remove debris or foreign object from augers / impeller.

REPAIR PARTS

AUGER HOUSING / IMPELLER ASSEMBLY

SNOW THROWER - MODEL NO. 9027ST (HU9027STA), PRODUCT NO. 954 22 30-74

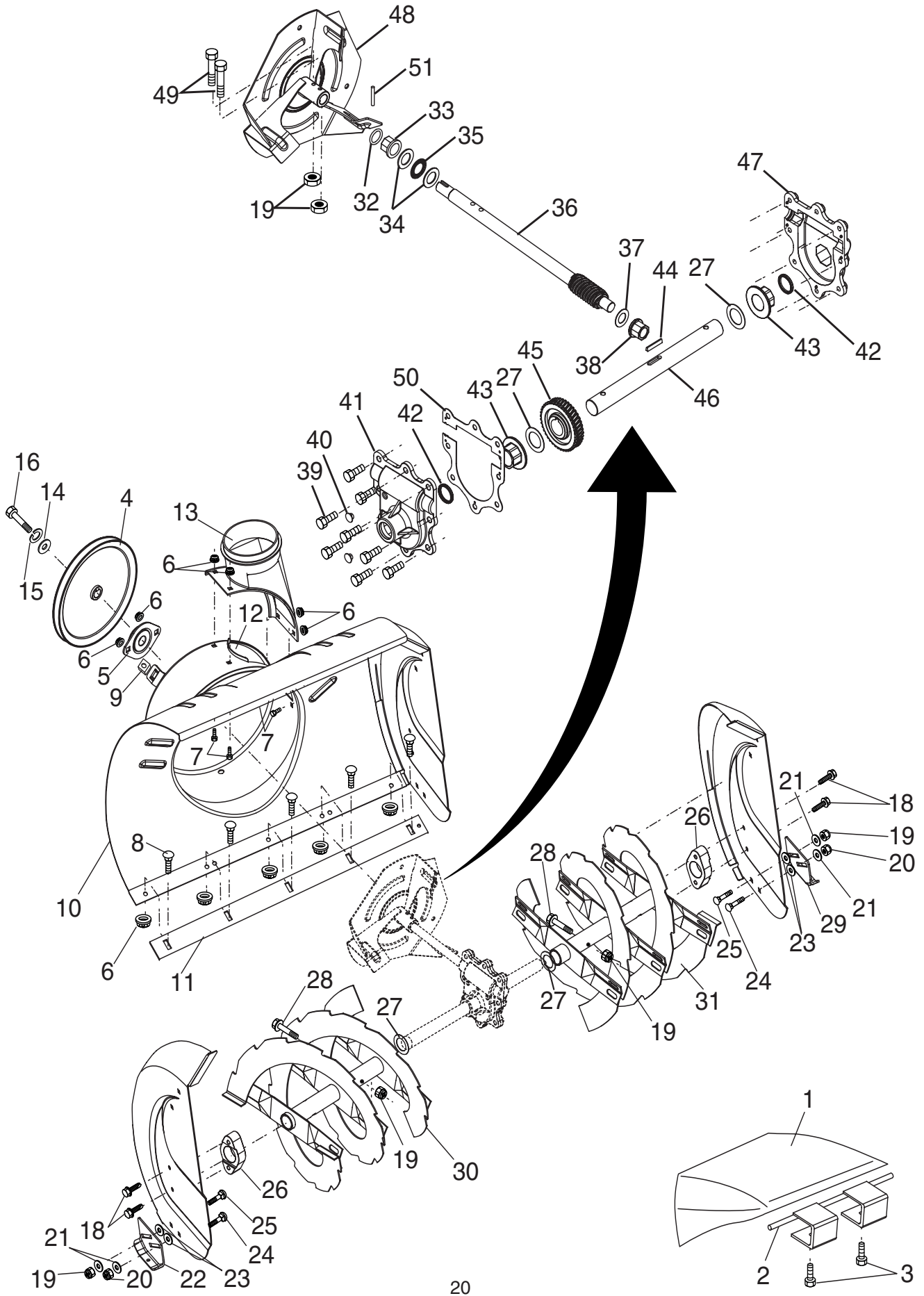

REPAIR PARTS**AUGER HOUSING / IMPELLER ASSEMBLY****SNOW THROWER - MODEL NO. 9027ST (HU9027STA), PRODUCT NO. 954 22 30-74**

KEY NO.	PART NO.	DESCRIPTION
1	532 18 35-78	Bag, Weight
2	532 18 35-77	Bracket, Weight Bag
3	874 52 05-24	Screw, Hex Head 5/16-18 x 1-1/2
4	532 18 10-83	Pulley, Impeller
5	532 17 53-23	Bearing Assembly, Flange
6	532 15 53-77	Nut, Hex Flange 5/16-18
7	532 18 03-55	Bolt, Flat Head, Carriage 5/16-18 x 5/8
8	872 27 05-05	Bolt, Carriage 5/16-1 8 x 5/8
9	532 17 88-20	Nut, Cage 3/8-16
10	532 18 40-91	Housing, Auger
11	532 18 40-97	Bar, Scraper
12	532 18 40-95	Bracket, Corner Discharge
13	532 17 53-22	Base, Discharge Chute
14	532 05 92-89	Washer, Flat
15	810 04 05-00	Washer, Lock 5/16
16	874 95 05-12	Screw, Hex Head 5/16-18 x 3/4
18	532 17 95-82	Screw, Hex Head 5/16 x 1
19	873 80 04-00	Nut, Hex Lock 1/4-20
20	873 80 05-00	Nut, Hex Lock 5/16-18
21	532 15 54-15	Washer, Flat
22	532 18 40-94	Skid Plate, RH
23	532 17 92-46	Washer, Nylon, Friction
24	872 27 05-06	Bolt, Carriage 5/16-18 x 3/4
25	532 17 98-29	Bolt, Shoulder
26	532 17 46-58	Bearing, Auger
27	532 17 46-97	Washer, Thrust, 1"
28	532 17 98-28	Bolt, Shoulder 1/4-20 x 2
29	532 18 40-93	Skid Plate, LH
30	532 18 41-03	Auger Assembly, RH
31	532 18 41-00	Auger Assembly, LH
32	532 17 46-99	O-Ring
33	532 17 47-00	Bushing, Flange 3/4
34	532 17 46-81	Washer, Thrust 3/4
35	532 17 46-84	Bearing, Thrust 3/4
36	532 17 46-60	Shaft, Impeller
37	532 17 46-83	Washer, Thrust 5/8
38	532 17 46-86	Bushing, Flange 5/8
39	532 15 00-78	Screw, Hex Head 5/16-18 x 3/4
40	532 08 64-47	Plug, Case
41	532 17 46-88	Housing, Gearbox, RH
42	532 17 46-98	Seal, Oil
43	532 17 47-01	Bushing, Flange, 1"
44	532 17 88-79	Key, Square 1/4 x 1/4 x 7/8
45	532 17 46-59	Gear, Worm
46	532 17 46-57	Shaft, Auger
47	532 17 46-87	Housing, Gearbox, LH
48	532 18 41-05	Impeller Assembly
49	874 78 04-26	Screw, Hex Head 1/4-20 x 1-5/8
50	532 17 53-11	Gasket, Gearbox
51	532 18 42-05	Pin, Roll 3/16 x 1-1/8

NOTE: All component dimensions given in U.S. inches
1 inch = 25.4 mm

REPAIR PARTS

CONTROL PANEL / DISCHARGE CHUTE

SNOW THROWER - MODEL NO. 9027ST (HU9027STA), PRODUCT NO. 954 22 30-74

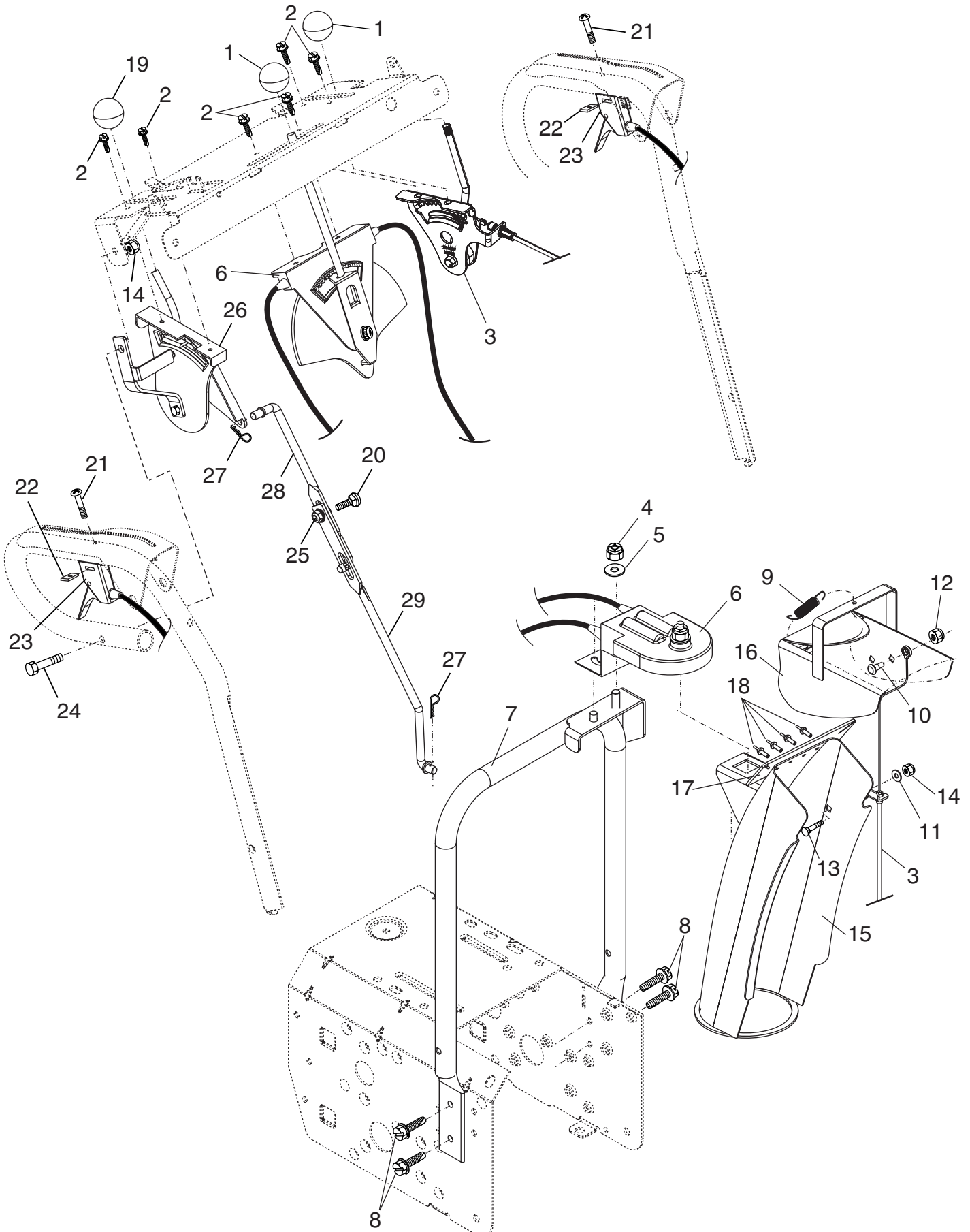

REPAIR PARTS**CONTROL PANEL / DISCHARGE CHUTE****SNOW THROWER - MODEL NO. 9027ST (HU9027STA), PRODUCT NO. 954 22 30-74**

KEY NO.	PART NO.	DESCRIPTION
1	532 18 33-34	Knob, Lever
2	817 50 10-10	Screw #10-24 x 5/8
3	532 17 86-74	Control Assembly, Deflector
4	873 80 06-00	Nut, Lock 3/8-16
5	819 13 13-16	Washer, Flat 3/8
6	532 17 86-59	Control Assembly, Chute Rotater
7	532 18 40-89	Support, Pivot
8	532 15 00-78	Screw, Hex Head 5/16-18 x 3/4
9	532 18 35-25	Spring, Deflector
10	532 17 98-29	Bolt, Shoulder
11	532 15 54-15	Washer, Flat
12	873 80 04-00	Nut, Lock 1/4-20
13	872 25 05-05	Bolt, Carriage 5/16-18
14	873 80 04-00	Nut, Lock 5/16-18
15	532 18 41-12	Chute Assembly
16	532 18 41-13	Deflector Assembly
17	532 17 91-45	Seal, Deflector
18	532 12 84-15	Rivet, Blind
19	532 18 33-33	Knob, Speed Control Lever
20	872 27 05-06	Bolt, Carriage 5/16-18 x 3/4
21	874 04 10-24	Screw #10-24 x 1-1/2
22	532 18 32-92	Nut, Weld #10-24
23	532 17 91-56	Control Assembly, Power Steering
24	874 78 05-28	Screw, Hex Head 5/16-18 x 1-3/4
25	532 15 53-77	Nut, Lock 5/16-18
26	532 17 92-57	Lever Assembly, Speed Control
27	532 16 96-75	Retainer, Hairpin
28	532 18 04-45	Rod, Upper, Speed Control
29	532 17 92-49	Rod, Lower, Speed Control

NOTE: All component dimensions given in U.S. inches
1 inch = 25.4 mm

REPAIR PARTS

HANDLES

SNOW THROWER - MODEL NO. 9027ST (HU9027STA), PRODUCT NO. 954 22 30-74

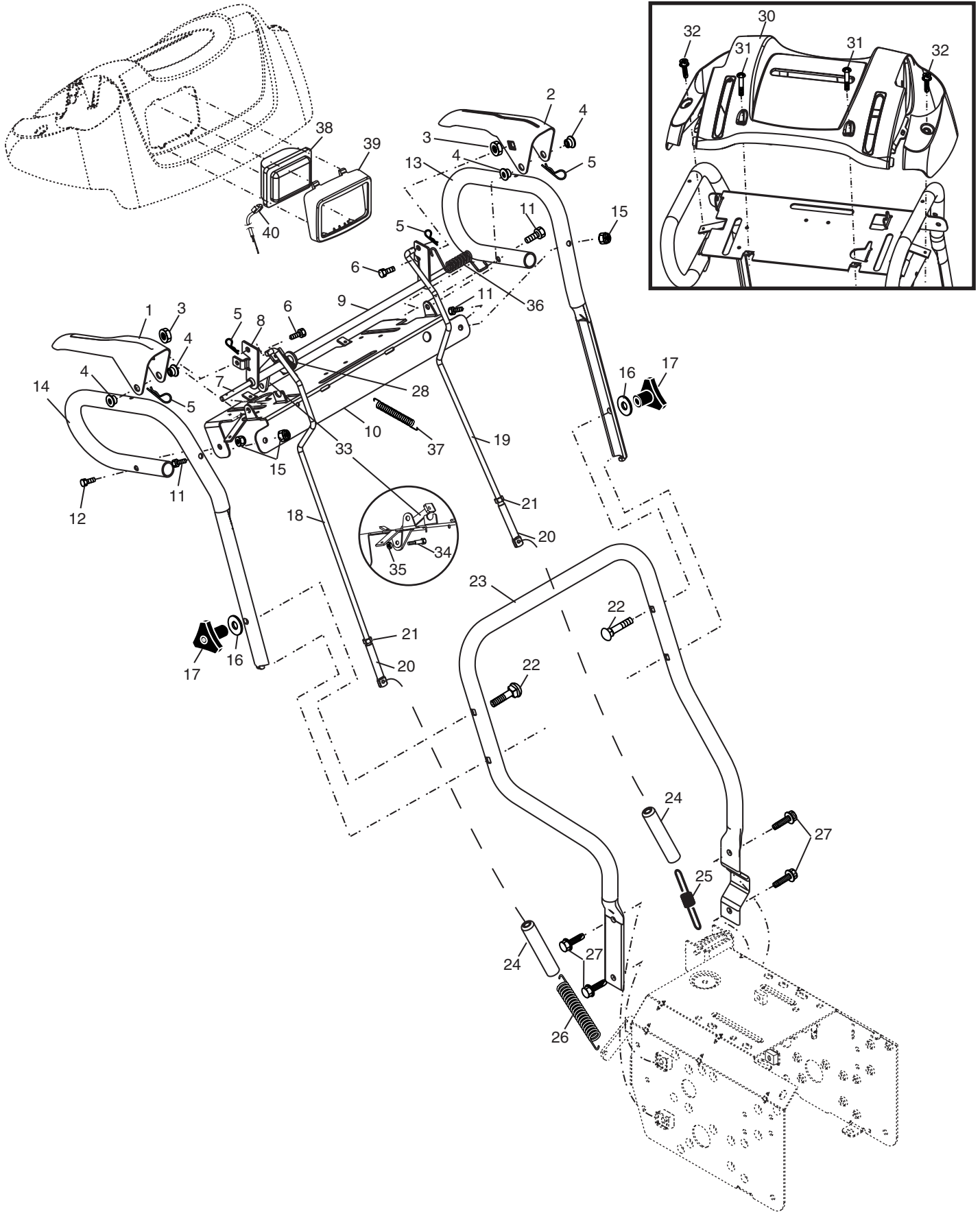

REPAIR PARTS**HANDLES****SNOW THROWER - MODEL NO. 9027ST (HU9027STA), PRODUCT NO. 954 22 30-74**

KEY NO.	PART NO.	DESCRIPTION
1	532 18 41-10	Lever, Auger Control, RH
2	532 18 41-09	Lever, Traction Drive Control, LH
3	532 17 94-39	Nut, Cage 1/4-20
4	532 17 88-88	Bushing, Flange
5	532 16 96-75	Retainer, Hairpin
6	532 18 04-02	Screw, Hex Head 1/4-20 x 3/4
7	532 17 86-52	Rod, Interlock
8	532 18 40-03	Tube Assembly, Interlock, RH
9	532 17 86-51	Tube Assembly, Interlock, LH
10	532 18 41-06	Panel, Control
11	874 78 05-24	Screw, Hex Head 5/16-18 x 1-1/2
12	874 78 05-28	Screw, Hex Head 5/16-18 x 1-3/4
13	532 18 41-07	Handle Tube, LH
14	532 18 41-08	Handle Tube, RH
15	873 80 05-00	Nut, Lock 5/16-18
16	819 13 13-16	Washer, Flat 3/8
17	532 17 88-99	Knob, Handle
18	532 17 90-93	Rod, Auger Control
19	532 17 90-98	Rod, Traction Control
20	532 18 04-28	End, Control Rod
21	873 35 05-00	Nut, Hex, Jam 5/16-18
22	872 12 06-18	Bolt, Carriage 3/8-16 x 2-1/4
23	532 18 40-88	Handle Tube, Lower
24	532 18 04-47	Sleeve, Spring
25	532 18 09-26	Spring, Traction Drive
26	532 17 86-69	Spring, Auger Control
27	871 21 06-16	Screw, Hex Head 3/8-16 x 1
28	532 18 04-94	Clip, Panel
30	532 18 29-06	Console, Panel
31	532 17 52-62	Screw, Hex Head, Tapping #10-24 x 1-1/4
32	532 75 06-34	Screw, Hex Head, Tapping #10-24 x 1/2
33	532 18 41-11	Latch, Interlock
34	532 18 35-18	Bolt, Shoulder
35	532 06 80-38	Nut, Lock 1/4-20
36	532 17 88-31	Spring, Torsion
37	532 17 86-58	Spring, Interlock
38	532 17 86-66	Headlight, Halogen
39	532 17 86-68	Bezel, Headlight
40	532 18 09-64	Harness, Headlight (Halogen)

NOTE: All component dimensions given in U.S. inches
1 inch = 25.4 mm

REPAIR PARTS

DRIVE

SNOW THROWER - MODEL NO. 9027ST (HU9027STA), PRODUCT NO. 954 22 30-74

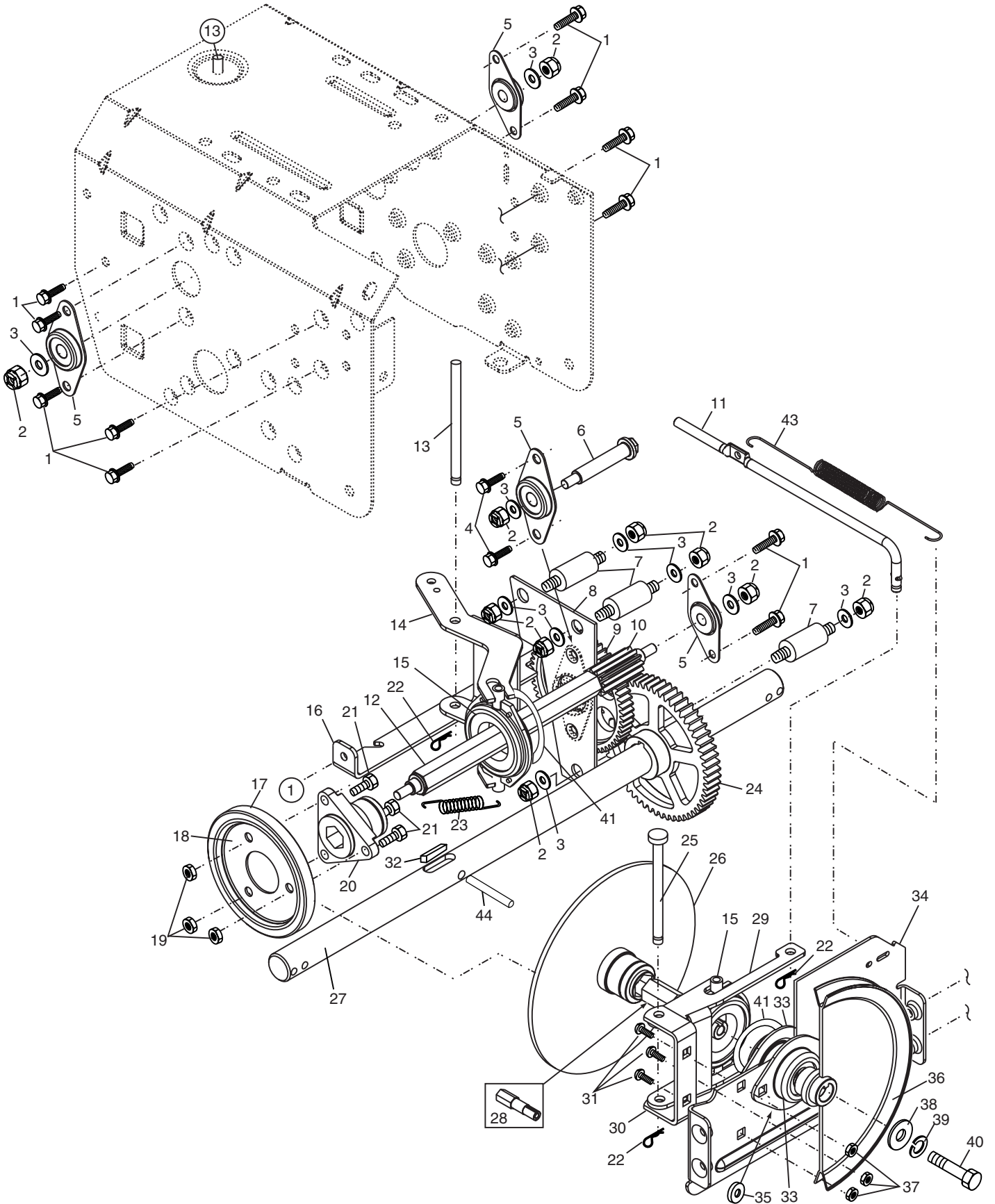

REPAIR PARTS**DRIVE****SNOW THROWER - MODEL NO. 9027ST (HU9027STA), PRODUCT NO. 954 22 30-74**

KEY NO.	PART NO.	DESCRIPTION
1	532 14 63-15	Screw, Hex Head 5/16-18 x 3/4
2	873 80 05-00	Nut, Lock 5/16-18
3	532 15 54-15	Washer, Flat
4	817 49 05-08	Screw, Hex Head 5/16-18 x 1/2
5	532 18 00-17	Bearing, Flange
6	532 18 01-34	Shaft, Auxiliary
7	532 17 92-70	Spacer, Plate
8	532 18 40-79	Plate, Auxiliary
9	532 18 00-82	Gear, Intermediate (12/58)
10	532 18 00-65	Gear, Pinion
11	532 17 88-12	Rod, Clutch
12	532 18 00-66	Shaft, Long, Hex
13	532 17 88-07	Pin, Pivot
14	532 18 40-80	Lever, Shifter / Wheel
15	532 17 53-44	Trunnion Bearing Assembly
16	532 18 40-81	Bracket, Pivot, Shift
17	532 17 98-31	Ring, Rubber Wheel
18	532 18 40-78	Plate, Rubber Wheel
19	873 93 05-00	Nut, Lock 5/16-18
20	532 17 86-13	Hub, Rubber Wheel
21	874 76 05-14	Screw, Hex Head 5/16-18 x 7/8
22	532 08 51-79	Retainer, Hairpin
23	532 18 01-35	Spring, Bias
24	532 18 00-81	Gear, Axle (58 Teeth)
25	532 17 86-95	Pin, Pivot Lever
26	532 17 53-41	Plate Assembly, Drive
27	532 17 86-21	Shaft, Axle
28	532 17 53-40	Shaft, Short Hex
29	532 18 40-77	Lever, Shifter Plate
30	532 18 40-76	Bracket, Shifter Support
31	872 27 05-05	Bolt, Carriage 5/16-18 x 5/8
32	532 17 88-79	Key, Square 1/4 x 1/4 x 7/8
33	532 17 53-23	Bearing, Flange
34	532 18 40-75	Plate, Drive Mounting
35	532 18 25-04	Spacer, Bearing
36	532 17 53-48	Pulley, Traction Drive
37	532 15 53-77	Nut, Lock 5/16-18
38	532 05 92-89	Washer, Flat
39	810 04 05-00	Washer, Lock 5/16
40	874 95 05-12	Screw, Hex Head 5/16-18 x 3/4
41	812 00 00-12	Ring, Retaining
43	532 17 90-95	Spring, Return
44	532 18 42-06	Pin, Roll

NOTE: All component dimensions given in U.S. inches
1 inch = 25.4 mm

REPAIR PARTS

CHASSIS / ENGINE / PULLEYS

SNOW THROWER - MODEL NO. 9027ST (HU9027STA), PRODUCT NO. 954 22 30-74

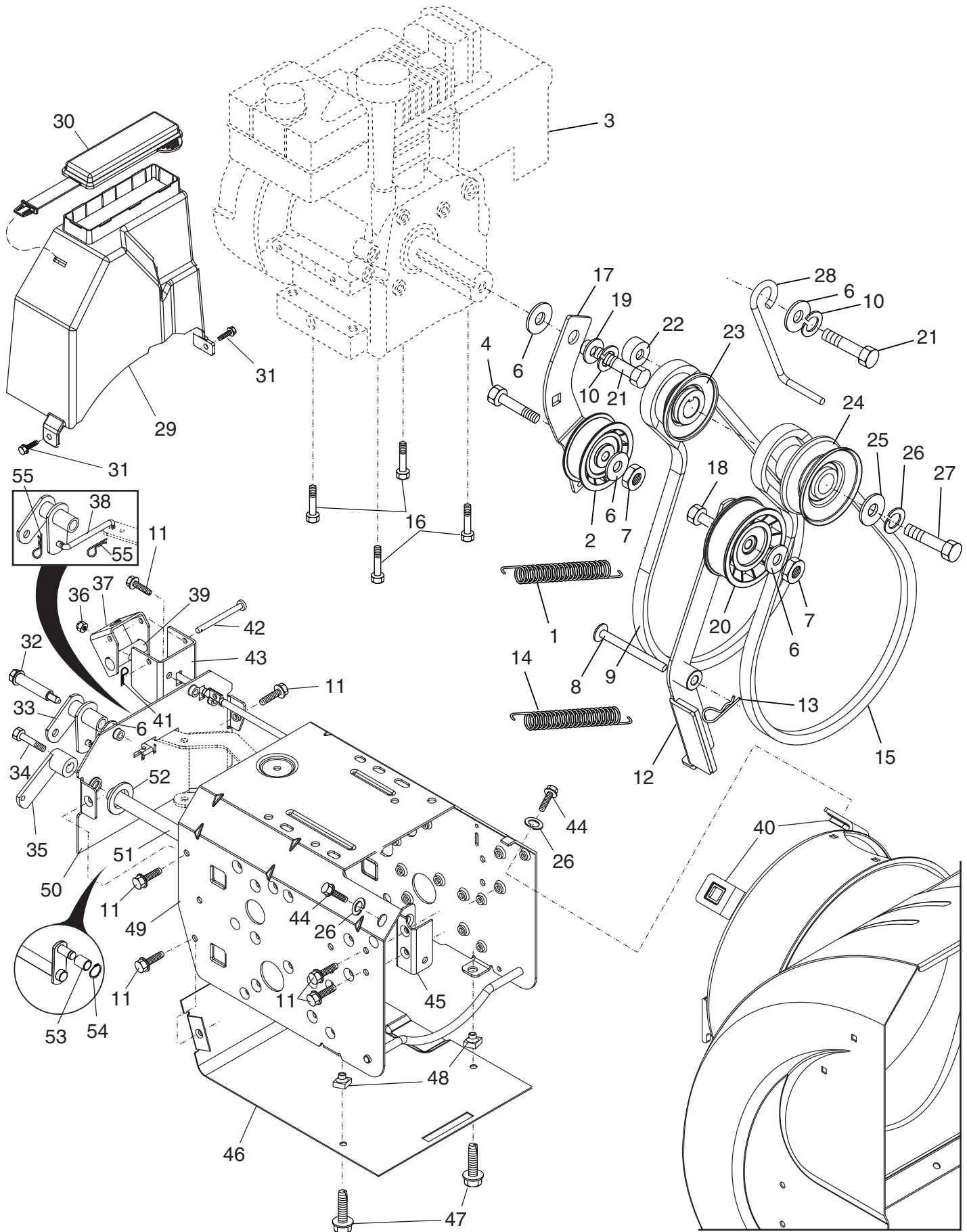

REPAIR PARTS**CHASSIS / ENGINE / PULLEYS****SNOW THROWER - MODEL NO. 9027ST (HU9027STA), PRODUCT NO. 954 22 30-74**

KEY NO.	PART NO.	DESCRIPTION
1	532 18 10-44	Spring, Traction Idler
2	532 18 05-22	Pulley, Idler (2-1/4)
3	- - -	Engine, Tecumseh, Model Number OHSK90 (Order parts from Engine manufacturer)
4	874 78 05-20	Screw, Hex Head 5/16-18 x 1-1/4
6	532 05 92-89	Washer, Flat
7	873 93 05-00	Nut, Jam, Lock 5/16-18
8	532 17 53-30	Pin, Idler Pivot
9	532 17 90-92	V-Belt, Traction Drive
10	810 04 05-00	Washer, Lock 5/16
11	532 15 00-78	Screw, Hex Head 5/16-18 x 3/4
12	532 18 47-89	Arm & Bracket Assembly, Impeller Idler (Includes Key Nos. 8, 12, 13 & 45)
13	532 08 51-79	Retainer, Hairpin
14	532 17 88-28	Spring, Brake
15	532 18 35-33	V-Belt, Impeller Drive
16	532 15 04-06	Screw, Hex Head 3/8-16 x 1-1/4
17	532 18 48-04	Arm, Idler
18	874 78 05-24	Screw, Hex Head 5/16-18 x 1-1/2
19	532 17 53-31	Bushing, Idler Pivot
20	532 18 05-23	Pulley, Idler (2-3/4)
21	874 61 05-16	Screw, Hex Head 5/16-18 x 1
22	532 17 93-71	Spacer, Engine Pulley
23	532 18 04-78	Pulley, Engine, Traction Drive
24	532 17 91-57	Pulley, Engine, Impeller Drive
25	532 06 27-35	Washer, Flat 3/8
26	810 04 06-00	Washer, Lock 3/8
27	532 85 10-84	Screw, Hex Head 3/8-24 x 1-3/8
28	532 15 54-52	Guide, Belt
29	532 18 04-65	Cover, Belt
30	532 17 88-30	Cover, Toolbox
31	817 49 04-08	Screw, Hex Head 1/4-20 x 1/2
32	532 17 92-56	Bolt, Shoulder 5/16-18
33	532 17 92-50	Bellcrank Shifter
34	532 18 04-01	Screw, Hex Head 1/4-28 x 3/4
35	532 17 92-40	Arm, Auger Control
36	873 80 05-00	Nut, Lock 5/16-18
37	532 18 40-86	Bellcrank Assembly
38	532 17 92-51	Link, Speed Control
39	532 17 90-64	Trunnion, Pivot Bracket
40	532 17 88-90	Nut, Cage 3/8-16
41	876 02 02-08	Pin, Cotter 1/16 x 1/2
42	532 17 90-65	Pin, Pivot Bracket
43	532 18 40-85	Bracket, Bellcrank
44	874 78 06-24	Screw, Hex Head 3/8-16 x 1-1/2
45	532 18 47-89	Arm & Bracket Assembly, Impeller Idler (Includes Key Nos. 8, 12, 13 & 45)
46	532 18 40-84	Pan, Frame Bottom
47	871 02 05-12	Screw, Hex Head 5/16-18 x 3/4
48	532 18 11-56	Nut, Speed 5/16-18
49	532 18 40-73	Frame Assembly
50	532 18 40-83	Plate, Frame End
51	532 18 40-82	Shaft, Auger Control
52	532 05 70-79	Washer, Hardened
53	532 17 90-62	Roller
54	812 00 00-10	Ring, Retaining
55	532 70 02-79	Clip, Retainer

NOTE: All component dimensions given in U.S. inches. 1 inch = 25.4 mm

REPAIR PARTS

WHEELS / DECALS

SNOW THROWER - MODEL NO. 9027ST (HU9027STA), PRODUCT NO. 954 22 30-74

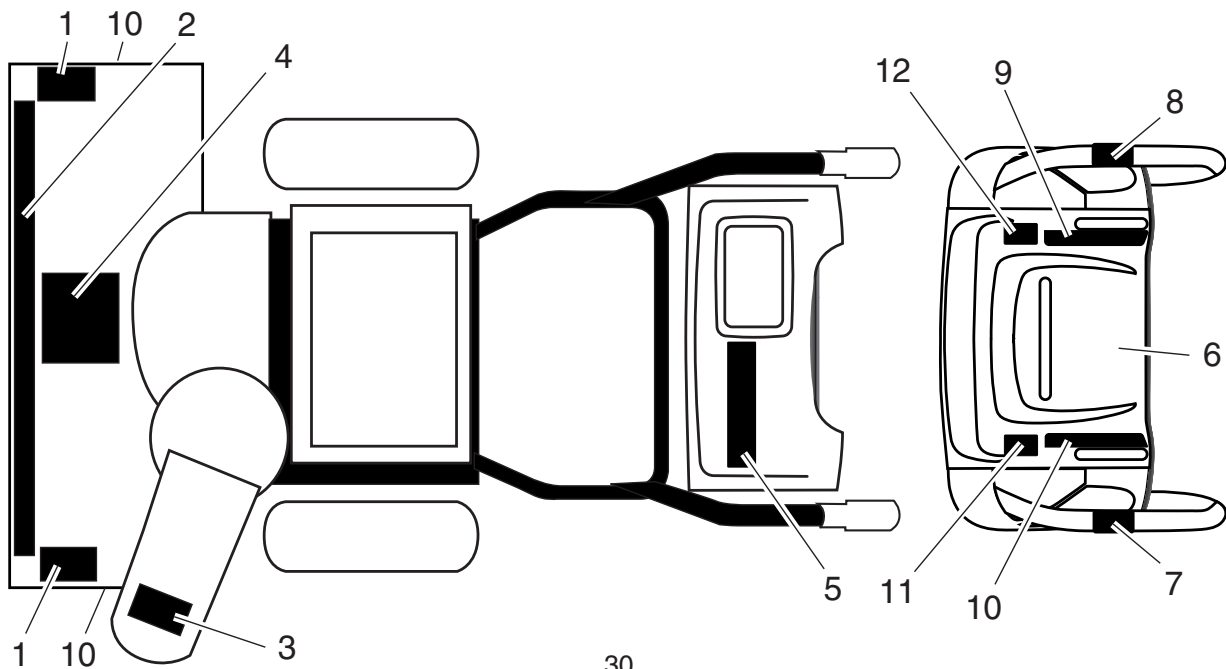
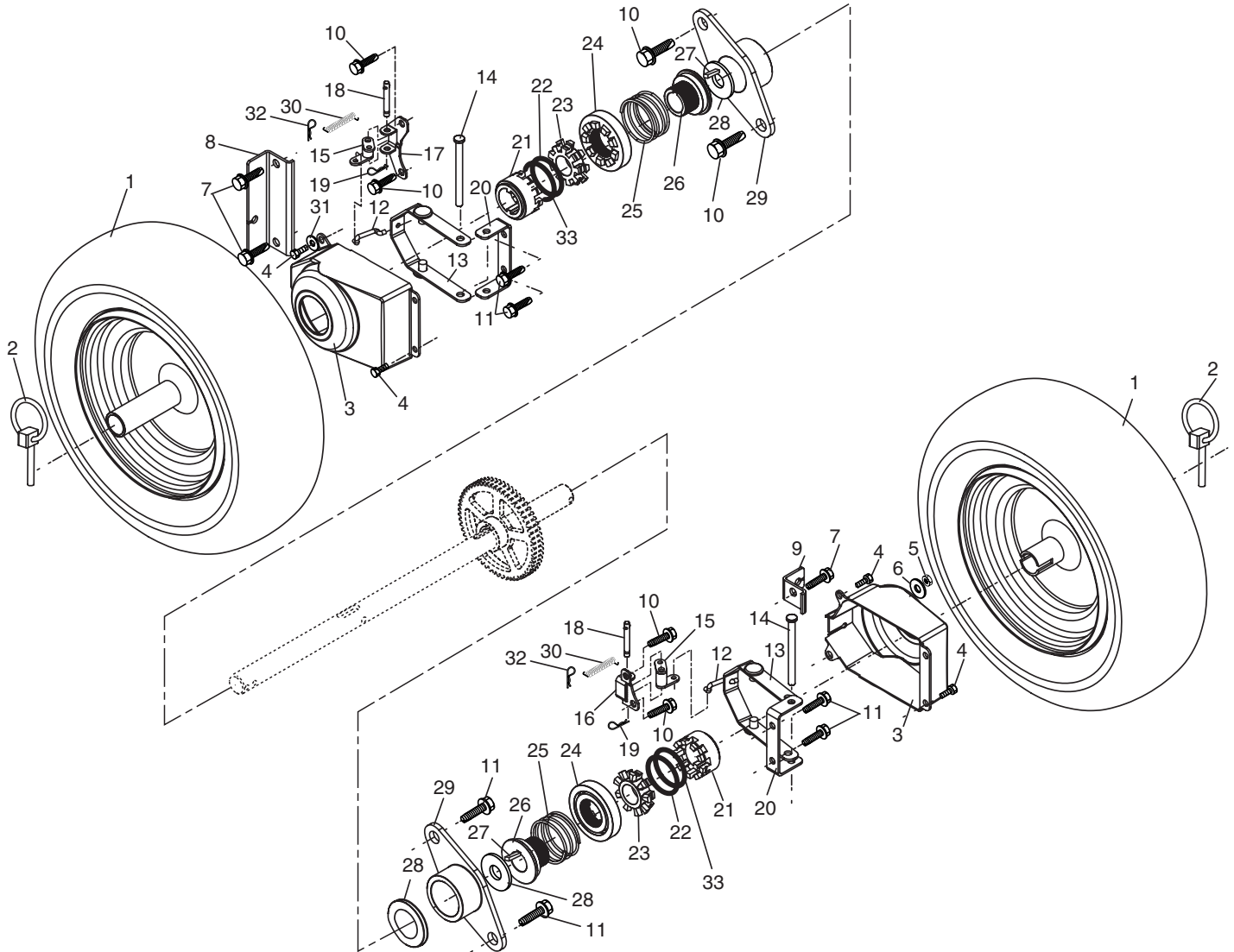

REPAIR PARTS**WHEELS / DECALS****SNOW THROWER - MODEL NO. 9027ST (HU9027STA), PRODUCT NO. 954 22 30-74**

KEY NO.	PART NO.	DESCRIPTION
1	532 17 88-34	Wheel Assembly (16" Power Steer)
2	532 15 54-43	Pin, Klik 1/4
3	532 18 18-43	Cover, Power Steering
4	817 54 10-08	Screw, Hex Head #10-24 x 1/2
5	873 80 05-00	Nut, Lock 5/16-18
6	532 15 54-15	Washer, Flat 5/16
7	871 21 06-16	Screw, Hex Head 3/8-16 x 1
8	532 18 42-00	Bracket, Steering Cable, RH
9	532 18 41-99	Bracket, Steering Cable, LH
10	532 15 00-78	Screw, Hex Head 5/16-18 x 3/4
11	817 49 05-08	Screw, Hex Head 5/16-18 x 1/2
12	532 18 43-93	Link, Steering Lever
13	532 18 45-29	Lever Assembly, Steering
14	532 18 20-15	Pin, Steering Lever
15	532 18 43-61	Bellcrank Assembly
16	532 18 19-82	Bracket Assembly, LH Steering
17	532 18 20-63	Bracket Assembly, RH Steering
18	532 18 18-47	Pin, Steering Bellcrank
19	532 08 51-79	Retainer, Hairpin
20	532 18 41-97	Bracket, Lever Assembly
21	532 17 91-41	Driver, Wheel
22	532 18 24-66	Ring, Wire Retainer
23	532 17 91-36	Lobe, Wheel
24	532 17 91-38	Slide, Clutch
25	532 17 91-39	Spring, Clutch Slide
26	532 17 91-37	Lobe, Axle
27	532 17 88-79	Key, Square 1/4
28	532 17 46-97	Washer, Thrust (1")
29	532 17 98-30	Bearing, Axle
30	532 18 22-26	Spring, Return
31	532 00 48-02	Washer, Flat
32	532 70 02-79	Clip, Retainer
33	812 00 00-45	Ring, Retaining

KEY NO.	PART NO.	DESCRIPTION
1	532 18 10-38	Decal, Danger
2	532 18 41-19	Decal, Husqvarna
3	532 18 10-34	Decal, Danger, Deflector
4	532 18 10-41	Decal, Danger
5	532 18 40-56	Decal, Husqvarna, 9027STE
6	532 18 10-32	Decal, Instruction
7	532 15 57-98	Decal, Traction Lever
8	532 15 58-00	Decal, Auger Lever
9	532 18 10-36	Decal, Speed Control
10	532 15 57-94	Decal, Husqvarna
11	532 18 39-07	Decal, LH Trigger
12	532 18 39-05	Decal, RH Trigger
--	532 18 35-27	Owner's Manual

NOTE: All component dimensions given in U.S. inches
1 inch = 25.4 mm



WARRANTY STATEMENT

SECTION 1: LIMITED WARRANTY

Husqvarna Forest & Garden Company ("Husqvarna") warrants Husqvarna product to the original purchaser to be free from defects in material and workmanship from the date of purchase for the "Warranty Period" of the product as set forth below:

Lifetime Warranty: All tiller tines against breakage, trimmer shafts, ignition coils and modules on hand held product.

3 Year Warranty: Spindles (on Zero Turn Riders and Commercial Walk-Behinds)

2 Year COMMERCIAL-Warranty: Husqvarna Commercial Turf Equipment—zero turn riders, wide area walks, and ground engaging commercial equipment.

2 Year NON-COMMERCIAL Warranty: Automatic Mower, Riding lawn mowers, yard and garden tractors, walk behind mowers, tillers, chain saws, trimmers, brushcutters, clearing saws, snow blowers, handheld blowers, backpack blowers, hedge trimmers, electrical products and power-assist collection systems for noncommercial, nonprofessional, noninstitutional or nonincome producing use, except as herein stated.

Emission control system components necessary to comply with CARB-TIER-II and EPA regulations, except for those components which are part of engine systems manufactured by third party engine manufacturers for which the purchaser has received a separate warranty with product information supplied at time of purchase.

1 Year Warranty: Power cutters, stump grinder, pole pruners and pole saws for non-commercial, non-professional, non-institutional or non-income producing use. All trimmers, brushcutters, clearing saws, hovering trimmers, stick edgers, backpack blowers, hand held blowers, hedge trimmers, power-assist collection systems used for commercial, institutional, professional or income producing purposes or use. Batteries have a one-year prorated limited warranty with 100% replacement during the first 6 months.

90 Day Warranty: Automatic Mower, Chain saws, power cutters, stump grinders, pole saws, pole pruners, snow throwers, model series 580 & 600 walk-behind mowers and commercial turf equipment or any Husqvarna product used for commercial, institutional, professional, or income producing purposes or use except as otherwise provided herein.

Husqvarna Safety Apparel carries a 90-day warranty from the date of the customer's original purchase for defects in material and workmanship. Normal wear, tear or abuse is not covered under warranty. Product must be returned to Charlotte with a warranty claim form. All care and maintenance instructions must be followed as stated by the manufacturer on the care label. The fit of the protective apparel/boot is not covered under warranty.

30 Day Warranty: Replacement parts, accessories including bars and chains, tools and display items.

SECTION 2: HUSQVARNA'S OBLIGATIONS UNDER THE WARRANTY

Husqvarna will repair or replace defective components without charge for parts or labor if a component fails because of a defect in material or workmanship during the warranty period.

SECTION 3: ITEMS NOT COVERED BY THIS WARRANTY

The following items are not covered by this warranty:

- (1) Normal customer maintenance items which become worn through normal regular use, including, but not limited to, belts, blades, blade adapters, bulbs, filters, guide bars, lubricants, rewind springs, saw chain, spark plugs, starter ropes and tines;
- (2) Natural discoloration of material due to ultraviolet light;
- (3) Engine and drive systems not manufactured by Husqvarna; these items are covered by the respective manufacturer's warranty as provided in writing with the product information supplied at the time of purchase; all claims must be sent to the appropriate manufacturer;
- (4) Lawn and garden attachments are covered by a third party which gives a warranty, all claims for warranty should be sent to the manufacturer; and
- (5) Emission Control System components necessary to comply with CARB-TIER-II and EPA regulations which are manufactured by third party engine manufacturer.

SECTION 4: EXCEPTIONS AND LIMITATIONS

This warranty shall be inapplicable to defects resulting from the following:

- (1) Accident, abuse, misuse, negligence and neglect, including stale fuel, dirt, abrasives, moisture, corrosion, or any adverse reaction due to incorrect storage or use habits;
- (2) Failure to operate or maintain the unit in accordance with the Owner's/Operator's manual or tion sheet furnished by Husqvarna;
- (3) Alterations or modifications that change the intended use of the product or affects the product's formance, operation, safety, or durability, or causes the product to fail to comply with any laws; or
- (4) Additional damage to parts or components due to continued use occurring after any of the

REPAIR OR REPLACEMENT AS PROVIDED UNDER THIS WARRANTY IS THE EXCLUSIVE REMEDY PURCHASER. HUSQVARNA SHALL NOT BE LIABLE FOR ANY INCIDENTAL OR CONSEQUENTIAL FOR BREACH OF ANY EXPRESS OR IMPLIED WARRANTY ON THESE PRODUCTS EXCEPT TO THE PROHIBITED BY APPLICABLE LAW. ANY IMPLIED WARRANTY OF MERCHANTABILITY OR FITNESS PARTICULAR PURPOSE ON THESE PRODUCTS IS LIMITED IN DURATION TO THE WARRANTY DEFINED IN THE LIMITED WARRANTY STATEMENT. HUSQVARNA RESERVES THE RIGHT TO CHANGE IMPROVE THE DESIGN OF THE PRODUCT WITHOUT NOTICE, AND DOES NOT ASSUME OBLIGATION UPDATE PREVIOUSLY MANUFACTURED PRODUCTS.

Some states do not allow the exclusion of incidental or consequential damages, or limitations on an implied warranty lasts, so the above limitations or exclusions may not apply to you. This warranty specific legal rights, and you may also have other rights which vary from state to state.

SECTION 5: CUSTOMER RESPONSIBILITIES

The product must exhibit reasonable care, maintenance, operation, storage and general upkeep in the maintenance section of the Owner's/Operator's manual. Should an operational problem or failure the product should not be used, but delivered as is to an authorized Husqvarna dealer for evaluation. purchase, as explained in section 6, rests solely with the customer.

SECTION 6: PROCEDURE TO OBTAIN WARRANTY CONSIDERATION

It is the Owner's and Dealer's responsibility to make certain that the Warranty Registration Card filled out and mailed to Husqvarna Forest & Garden Company. This card should be mailed within ten from the date of purchase in order to confirm the warranty and to facilitate post-sale service.

Proof of purchase must be presented to the authorized Husqvarna dealer in order to obtain warranty This proof must include date purchased, model number, serial number, and complete name and address selling dealer.

To obtain the benefit of this warranty, the product believed to be defective must be delivered authorized Husqvarna dealer in a timely manner, no later than thirty (30) days from date of the problem or failure. The product must be delivered at the owner's expense. Pick-up and delivery charges covered by this warranty. An authorized Husqvarna dealer can be normally located through the "Yellow of the local telephone directory or by calling 1-800-HUSKY62 for a dealer in your area.

HUSQVARNA
7349 Statesville Road
Charlotte, NC 28269

531 83 81-23

