

**Instruktion
Käyttöohjeet
Instruksjon
Bedienungsanleitung
Instructions**

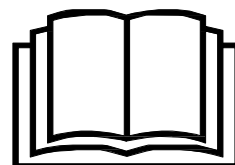

**SNÖSLUNGA
LUMILINKO
SNØFRESER
SCHNEESCHLEUDER
SNOW THROWER**

STIGA PARK

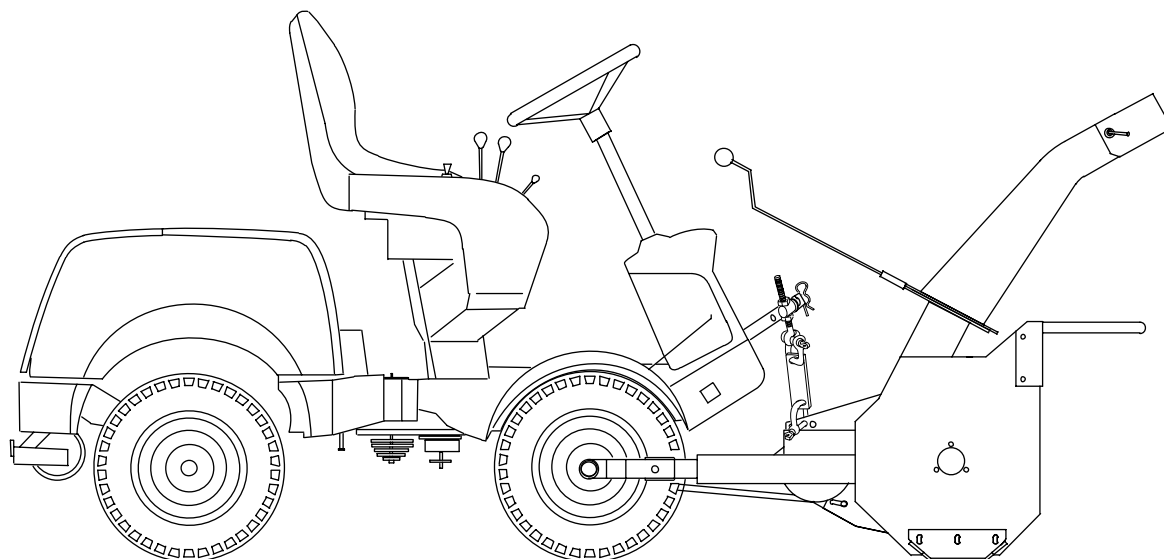

MADE IN FINLAND BY KOVA

**Type: PA407
Art. No: 13-1948-12**

STIGA

TRANÅS - SWEDEN

10127
1319-1745-02

ENGLISH



SAFETY REGULATIONS

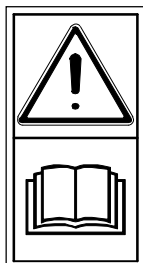

Study and understand the owner's manual before use.



Keep hands and feet away from the rotating parts of the snow thrower.



Turn the engine off before cleaning auger housing or discharge chute. Never put your foot or hand in the auger or in the discharge chute when the snow thrower is running.



Never direct discharge chute at bystanders, animals or windows.



Keep the area of operation clear of all persons, especially small children and pets.



Shut off engine before performing maintenance or repair work.

SAFETY PRECAUTIONS

1. Read the owner's instruction manual carefully.
2. Be thoroughly familiar with the controls and proper use of the equipment. Know how to stop the unit and disengage the controls quickly.
3. Never allow children to operate equipment. Never allow adults to operate equipment without proper instruction.
4. Keep the area of operation clear of all persons, especially small children and pets.
5. Exercise caution to avoid slipping or falling, especially when operating in reverse.
6. Thoroughly inspect the area where the equipment is to be used and remove all door mats, sleds, boards, wires and other foreign objects.
7. Disengage all clutches and shift into neutral before starting engine.
8. Do not operate equipment without wearing adequate winter outer garments. Wear footwear which will improve footing on slippery surfaces.

9. Never attempt to make any adjustment while engine is running.
10. Never operate the snow thrower without good visibility or light.
11. After striking foreign object, stop the engine, thoroughly inspect the snow thrower for any damage, and repair the damage before restarting and operating the snow thrower.
12. If the unit should start to vibrate abnormally, stop the engine and check immediately for the cause. Vibration is generally a warning of trouble.
13. Take all possible precaution when leaving the vehicle unattended, disengage the power take-off, lower the attachment, shift into neutral, set the parking brake, stop the engine, remove the key.
14. Never operate snow thrower without guards, plates or other safety protective devices in place.
15. Never direct discharge at bystanders or allow anyone in front of unit.
16. Do not run engine indoors, exhaust fumes are dangerous.

OPERATING TIPS

1. Whenever possible, discharge snow down wind.
2. Raise snow thrower when you drive between jobs.
3. Do not attempt to remove ice or hard packed frozen snow.
4. For best efficiency, clear snow before it melts, refreezes and hardens.
5. Do not overload machine capacity by attempting to clear snow at too fast rate.
6. If you are blowing snow where it is hilly use wheelweights STIGA 13-1982.

ENGLISH



SAFETY LABELS

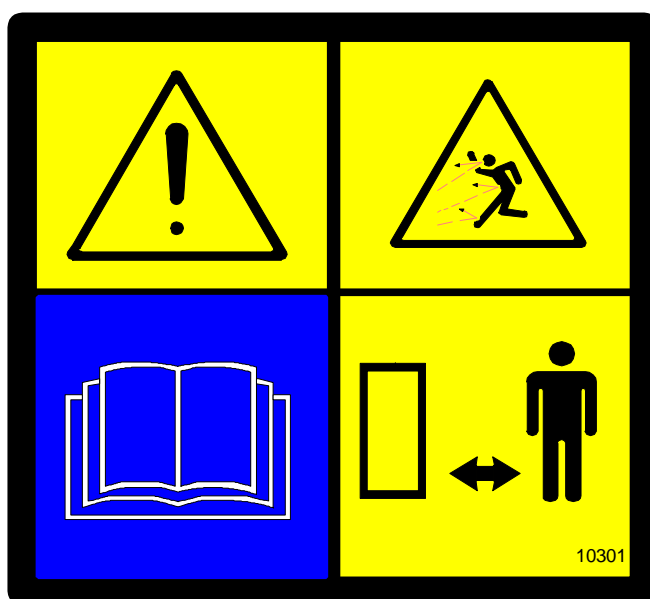
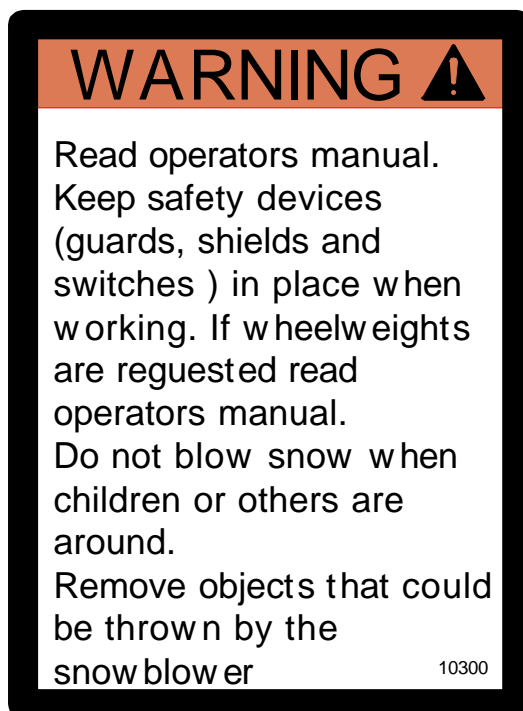

ENGLISH



SAFETY LABELS

 DANGER	
	
<p>Shut off engine before unblocking discharge chute.</p> <p>10302</p>	

 DANGER	
	
<p>Avoid injury from rotating auger. Keep hands, feet and clothing away</p>	<p>10303</p>

ASSEMBLY

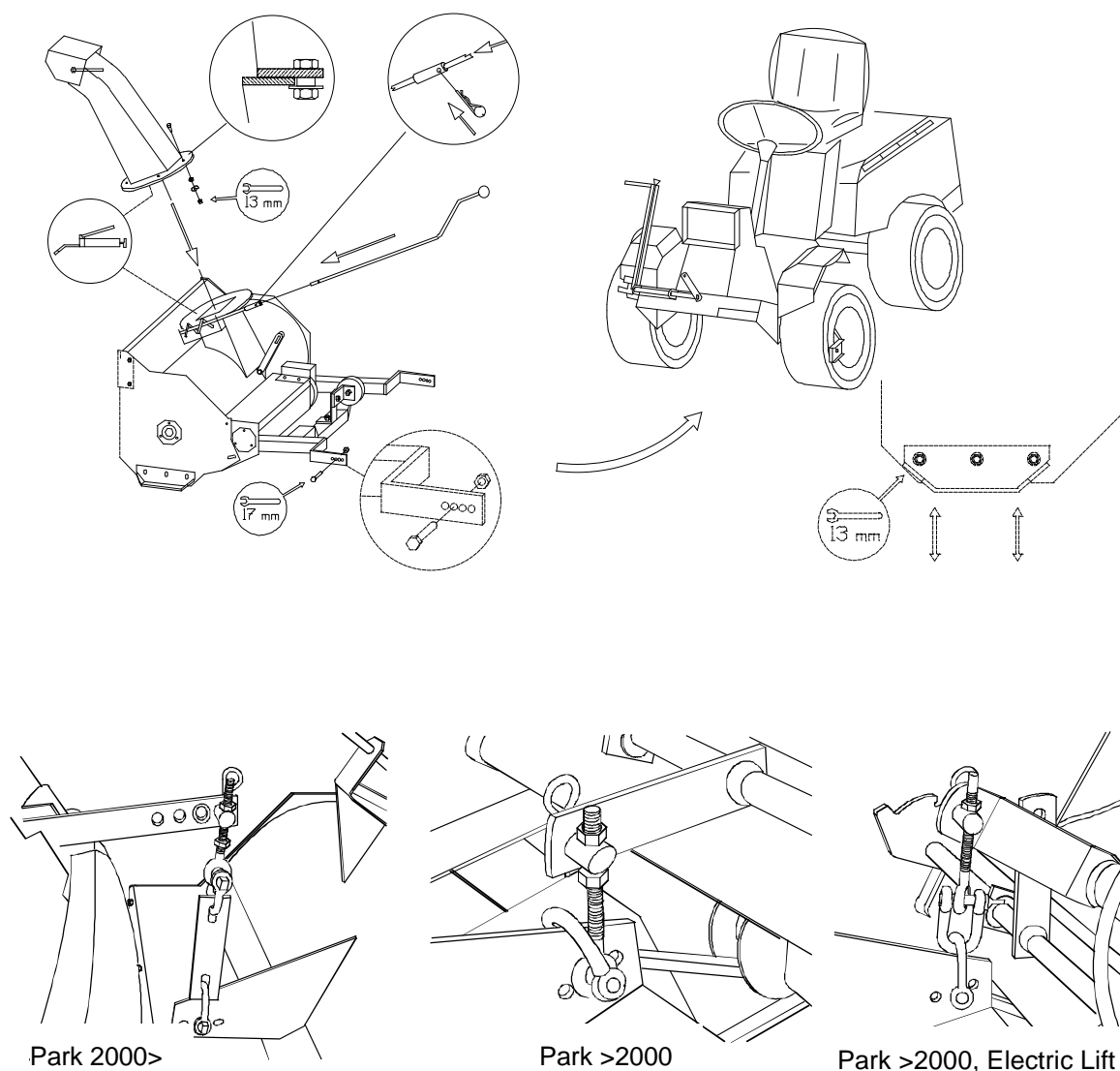

1. Remove the cutterhead from the machine.
2. Fit the deflector pipe.
3. Drive the machine up to the thrower and bolt the thrower to the attachment bracket.
4. Fit the snow thrower's lift arm to the attachment lift.
5. Fit the deflector pipe's turning lever on the thrower.
6. Fit the V-belt from the machine onto the thrower. **DO NOT LOOSEN AND REMOVE THE THROWER'S TENSION ROLLER OR BRACKET.** The tension roller is set at the factory.
7. Adjust the thrower's runners according to the ground and application.
8. Check that the guard is in good condition.

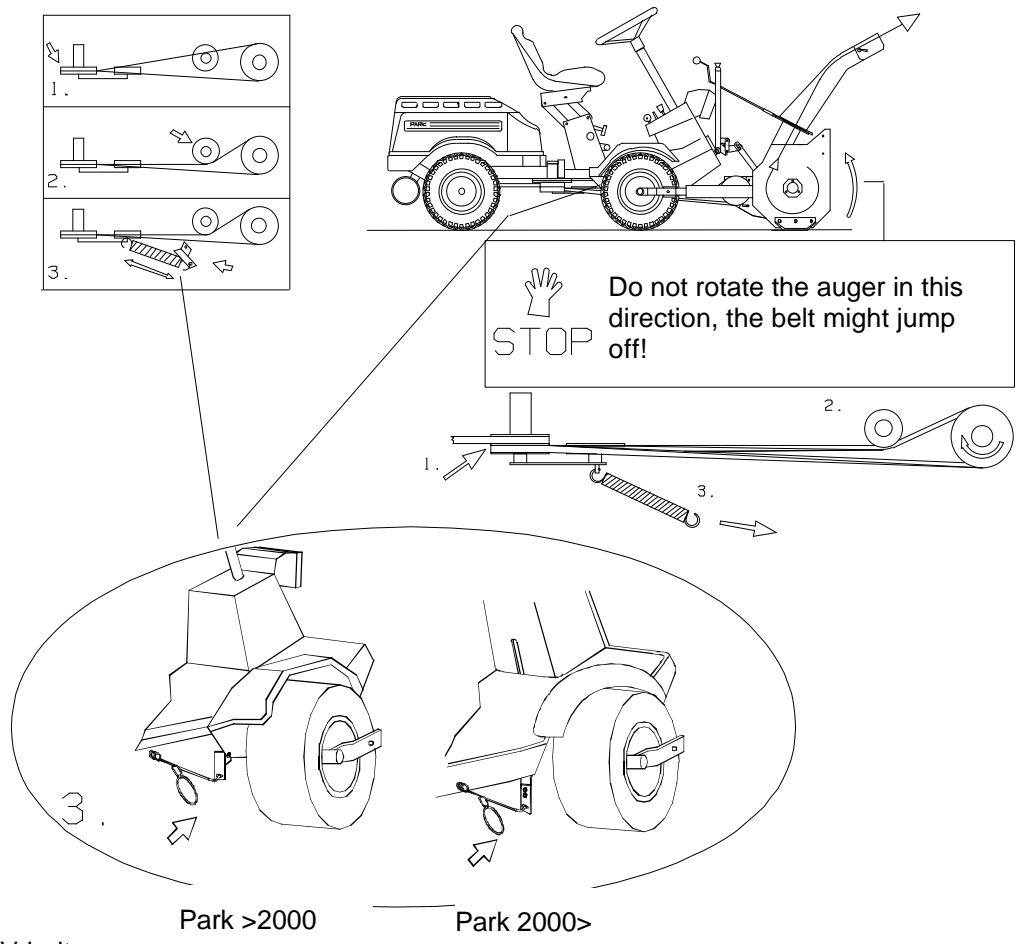

Fitting the V-belt

MAINTENANCE

ALWAYS STOP THE ENGINE before carry out maintenance or repairs.

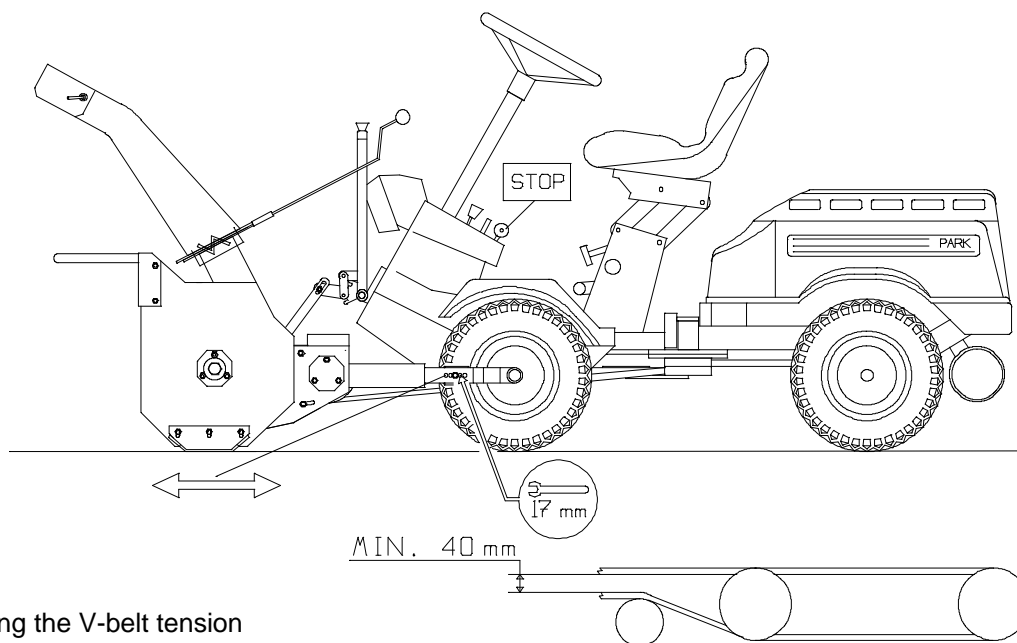

Adjusting the V-belt tension

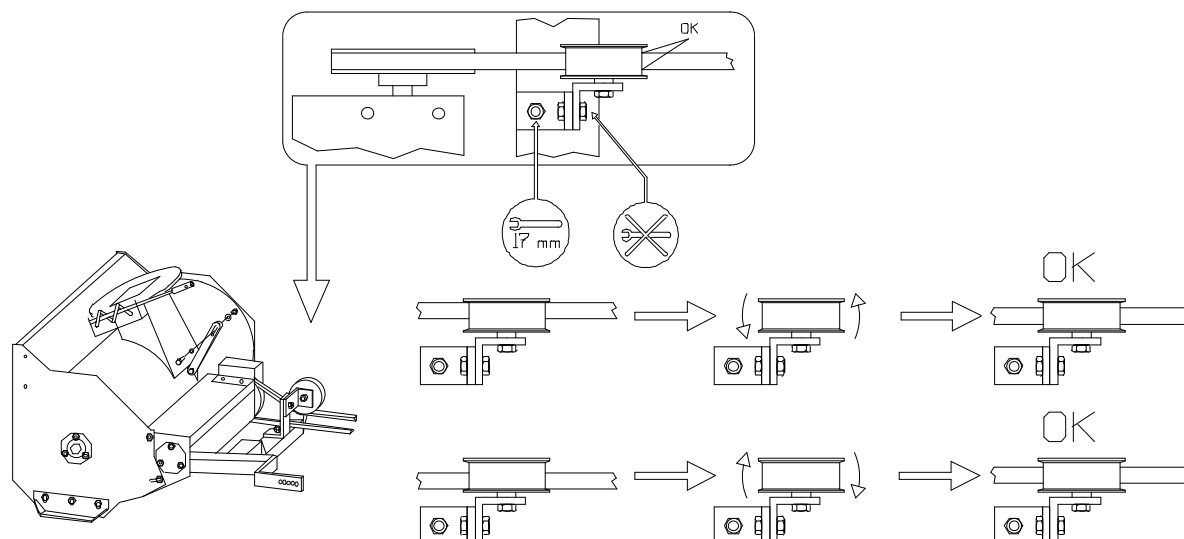

Adjusting the tension roller (carried out only if necessary)

Lubricate and tension (if necessary) the chain in the chain housing after every 5 hours of use. The tension is correct when the chain can be depressed 5 mm in its centre.

Irregular vibrations on the thrower are a sign that something is wrong. STOP THE ENGINE immediately and check the thrower, make any repairs before continuing.

STORAGE

Before storing for the summer any damaged areas should be prepared and painted. Thereafter apply a film of thin oil or grease on the thrower to prevent rusting.

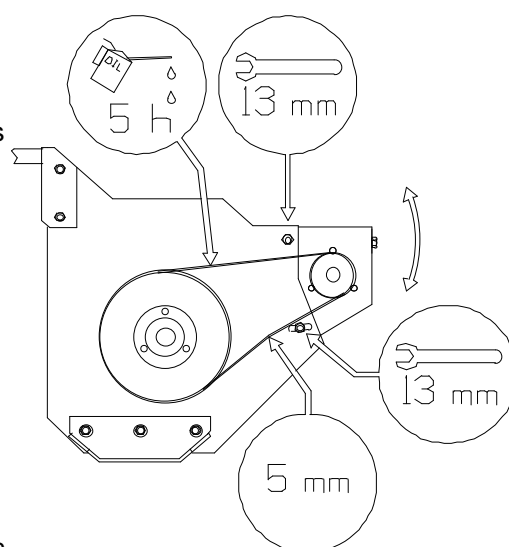

Adjusting the chain tension

TECHNICAL DATA:

- Single stage snow thrower for front attachment to Stiga Park.
- Deflector pipe manually adjustable through approx. 180 degrees.
- Throw direction controlled from the driver's seat.
- Manually adjustable deflector plate to control the throwing height
- Two adjustable runners.
- Mechanical drive via a V-belt.
- Chain driven feeder screw.
- Throwing length: up to 12 metres, depending on the speed and the consistency of the snow.
- Feeder screw speed 1300 r/min.
- Power requirement 5 kW.
- Working width 900 mm.
- Width 995 mm.
- Weight 65 kg.

Factory settings

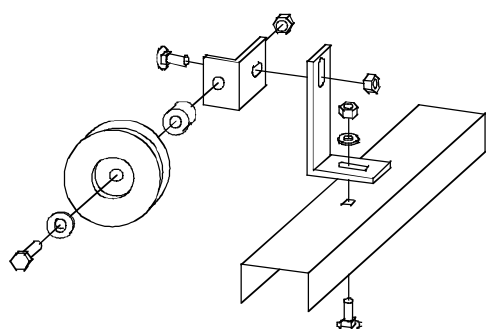
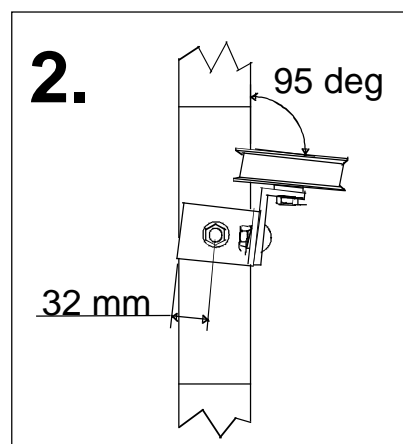
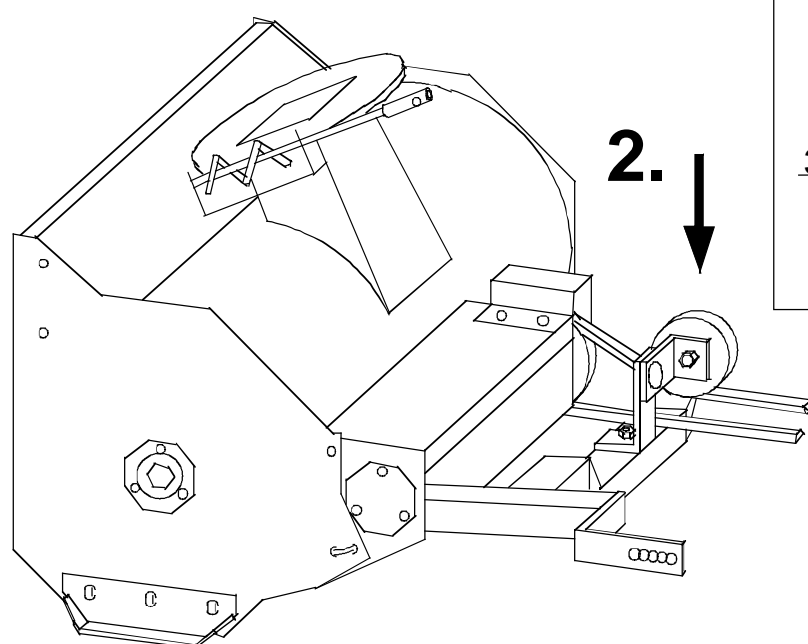
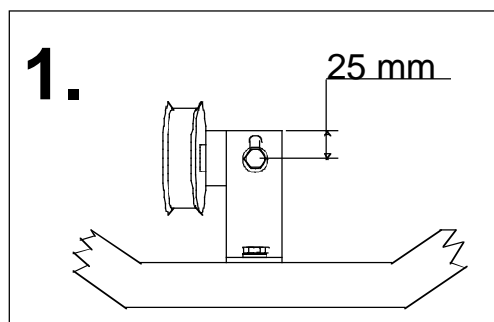
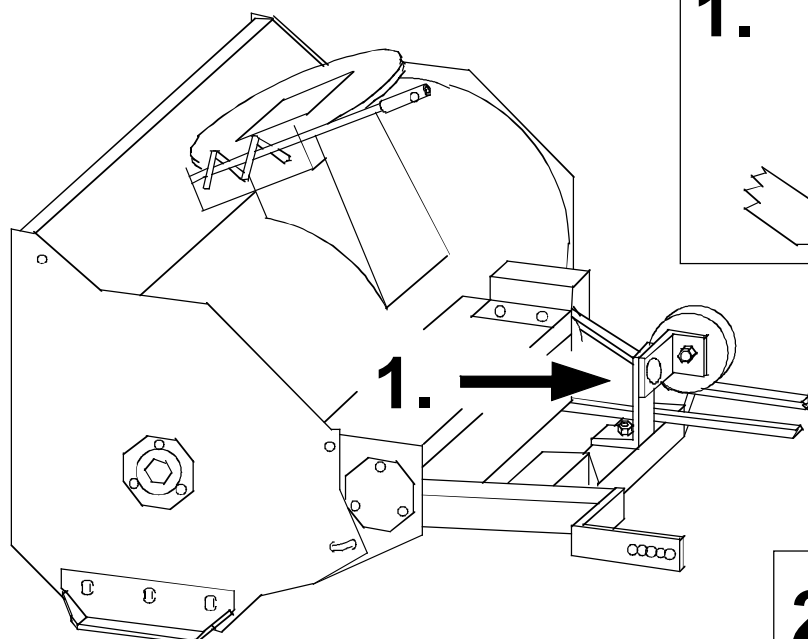

Type: PA407

Art. No: 13-1948-12

STIGA

TRANÅS - SWEDEN

INTYG**S**

Tillverkare: KONEPAJA A. VANNE, KOVA, Veistämöntie 16, FIN-24800 HALIKKO, FINLAND, försäkrar härmed att maskintyp PA407 är i överensstämmelse med maskindirektivet 89/392/EEC, 91/368/EEC, 93/44/EEC med särskilda hänvisningar till direktivets Annex 1 om väsentliga hälso och säkerhetskrav i samband med konstruktion och tillverkning.

Utfärdat i Halikko 2000

BESCHEINIGUNG**D**

Hersteller: KONEPAJA A. VANNE, KOVA, Veistämöntie 16, FIN-24800 HALIKKO, FINLAND, bestätigt hiermit, daß die Maschine vom Typ PA407 mit den Maschinenrichtlinien 89/392/EEC, 91/368/EEC, 93/44/EEC unter besonderem Hinweis auf ANNEX 1 der Richtlinie über die wichtigsten Gesundheits- und Sicherheitsanforderungen im Zusammenhang mit Konstruktion und Herstellung, übereinstimmt.

Ausgestellt in Halikko 2000

TODISTUS**FIN**

Valmistaja: KONEPAJA A. VANNE, KOVA, Veistämöntie 16, FIN-24800 HALIKKO, FINLAND, vakuuttaa, että kone tyyppi PA407 on koneidirektiivin 89/392/EEC, 91/368/EEC, 93/44/EEC mukainen huomioiden erityisesti oleelliset terveys- ja turvallisuusvaatimukset, jotka koskevat koneiden suunnittelua ja rakennetta.

Laadittu Halikossa 2000

ATTESTATION**F**

Fabricant: KONEPAJA A. VANNE, KOVA, Veistämöntie 16, FIN-24800 HALIKKO, FINLAND, atteste par la présente que la machine de type PA407 est conforme aux Directives Machines 89/392/EEC, 91/368/EEC, 93/44/EEC avec une référence particulière à l'Annexe 1 des directives, concernant les exigences principales en matière de santé et de sécurité au niveau de la construction et de la fabrication.

Fait à Halikko en 2000

BEVIS**DK**

Fremstiller: KONEPAJA A. VANNE, KOVA, Veistämöntie 16, FIN-24800 HALIKKO, FINLAND, forsikrer hermed, at maskinen af type PA407 er i overensstemmelse med Maskindirektiv 89/392/EEC, 91/368/EEC, 93/44/EEC med særlig henvisning til direktivets Annex 1 om væsentlige sundheds- og sikkerhedskrav i forbindelse med konstruktion og fremstilling.

Udfærdiget i Halikko 2000

CERTIFICATE**GB**

Manufacturer: KONEPAJA A. VANNE, KOVA, Veistämöntie 16, FIN-24800 HALIKKO, FINLAND, hereby certifies that the machine of type PA407 conforms to Machine Directive 89/392/EEC, 91/368/EEC, 93/44/EEC with special reference to Annex 1 of the directive concerning essential health and safety requirements in relation to design and manufacture.

Issued at Halikko 2000

ATTEST**N**

Produsent: KONEPAJA A. VANNE, KOVA, Veistämöntie 16, FIN-24800 HALIKKO, FINLAND, forsikrer herved at maskinen av type PA407 er i overensstemmelse med EUs Maskindirektiv 89/392/EEC 91/368/EEC, 93/44/EEC med særskilt henvisning til direktivets vedlegg 1 om vesentlige helse- og sikkerhetskrav i forbindelse med konstruksjon och produksjon.

Utfærdiget i Halikko 2000

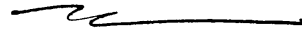

Ismo Forsström